

THE INFORMATION CONTAINED IN THIS DRAWING IS THE SOLE PROPERTY OF EASTERN INSTRUMENTS ANY REPRODUCTION IN PART OR WHOLE WITHOUT THE WRITTEN PERMISSION OF EASTERN INSTRUMENTS IS PROHIBITED.

High Beta Pharmaceutical (HBP) Overview Low Pressure Version Shown

REVISIONS			
REV.	DESCRIPTION	DATE	DRAWN BY

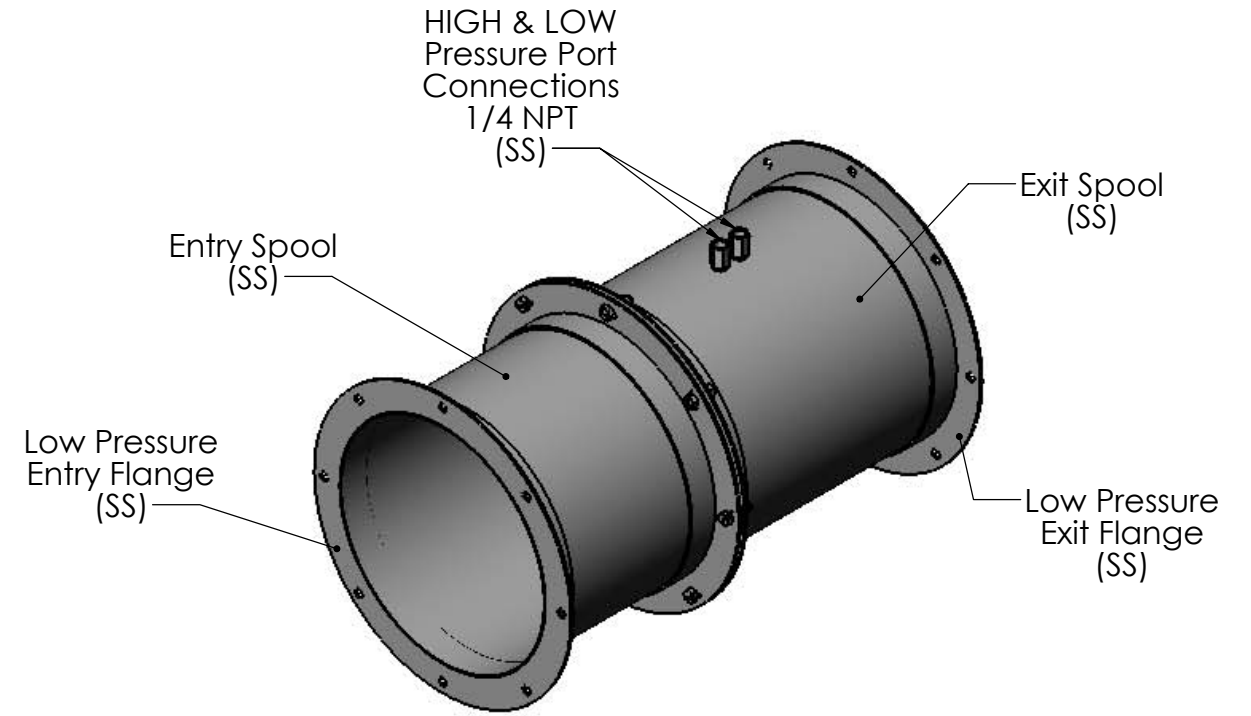
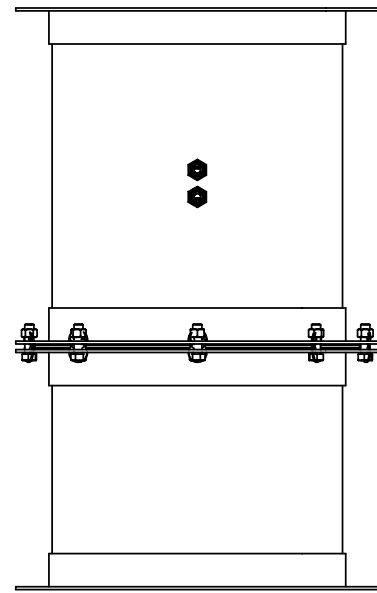

HBP-12-LP Shown

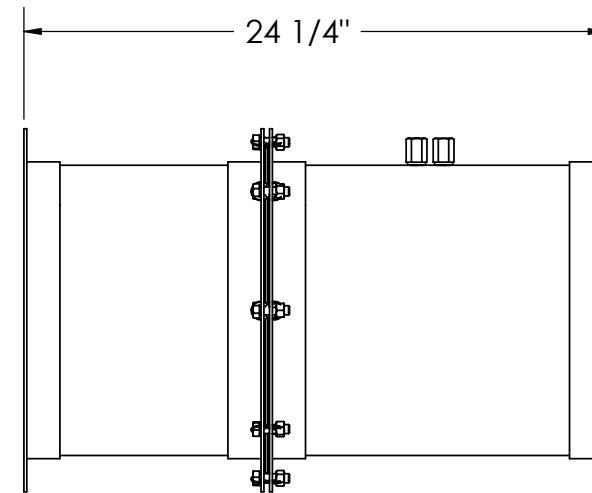
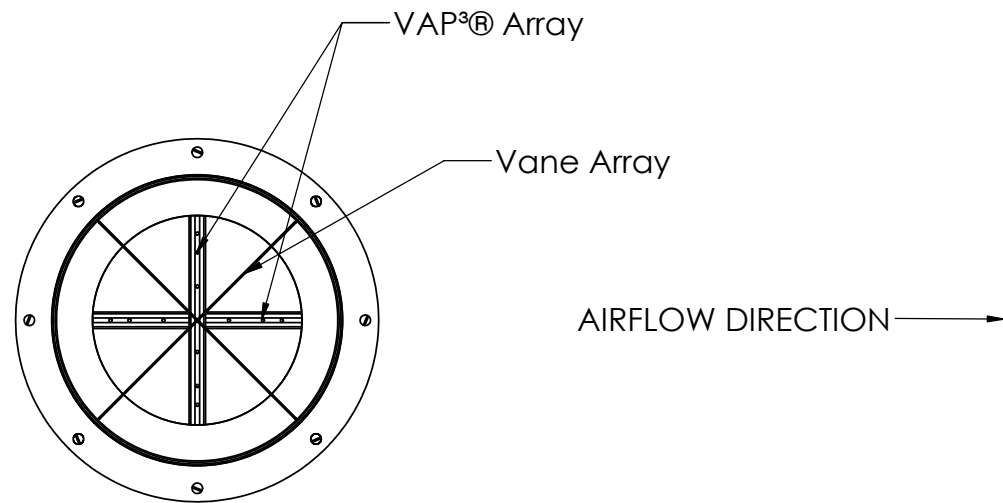

- GENERAL NOTES:
 1. BREAK ALL SHARP EDGES AND CORNERS.
 2. ALL DRILLED, TAPPED, AND BORED HOLES WILL HAVE A .01 X 45° CHAMFER
 3. WELD NOTES:
 a. ALL WELDS TO BE CONTINUOUS, FULL PENETRATION WELDS.
 b. WELDS TO BE FREE OF PIN HOLES, VOIDS, GAS OR SLAG POCKETS, AND CRACKS.
 c. WELD FINISH TO BE A FINE RIPPLE OR A 200 GRIT GRIND AS REQUIRED.
 d. WELDS TO BLEND WITH PARTS WITHOUT EXCESSIVE UNDERCUT OR OVERLAP.

UNLESS OTHERWISE SPECIFIED DIMENSIONS ARE IN IN [MM] TOLERANCES ARE: Decimal: +/- 0.005 [.13] Fractional: +/- 1/32 [.80] Angular: +/- 1/4°	CAD GENERATED DRAWING, DO NOT MANUALLY UPDATE	
	APPROVALS	DATE
	DRAWN bjb	10/10/05
	CHECKED	
	ENG CHK	
MATERIAL	Noted	
FINISH	32µin [0.8µm]	
DO NOT SCALE DRAWING	PROD CHK	

EASTERN INSTRUMENTS
 416 Landmark Drive
 Wilmington, NC 28412 USA
 sales@easterninstruments.com
 www.easterninstruments.com

High Beta Pharmaceutical
 HBP Sensor Overview
 Overview Drawing

QTY REQD
N/A

SIZE B DWG. NO. HBP Overview REV. 1

SCALE: 1:8 CAD FILE: .pdf SHEET 1 of 1