



EASTERN INSTRUMENTS

CENTRIFEEDER ELECTRONICS

FOR USE WITH CENTRIFEEDER with Integrated Control Valve (ICV)
or AUXILIARY FEEDER



REV 4/17

VERSION 6.5.0 SOFTWARE

Copyright© 2017 Eastern Instrument Laboratories, Inc.

All Rights Reserved.

416 Landmark Drive
Wilmington, NC 28412

www.easterninstruments.com

Phone:(910) 392-2490
Fax: (910) 392-2123



TABLE OF CONTENTS

SAFETY

Safe Operation.....	4
Warnings and Cautions	4
Safety Placards	5

INSTALLATION

1. Installation Guidelines	6
Requirements.....	6
Trouble Areas.....	6
Electronics Enclosure Drawing.....	7
Identifying Your Components: Electronics	8
Identifying Your Components: CentriFeeder with ICV	9
Identifying Your Components: Auxiliary Control	10
2. Wiring	11
Grounding the CentriFeeder.....	12
Wiring the Remote Electronics Cable at Meter Module: CentriFeeder with ICV	13
Wiring the Remote Electronics Cable at Meter Module: Auxiliary Control	14
Wiring Customer Connections at the Electronics Enclosure	15
Start/Stop Control: Auxiliary Feeder Only	16
Position Sensor - CentriFeeder with ICV	17
Wiring the Remote Electronics Cable	18
Customer Connections Outputs.....	19
Pulsed Air (Optional).....	21
Power: Electronics Enclosure.....	22
Power ICV Control Valve: CentriFeeder with ICV Only	23

OPERATION

3. Pulse Blast System.....	24
4. A Closer Look	26
5. Powering On	27
6. Security Features.....	29

PROCEDURES

7. Static Calibration	31
8. Site Calibration	33
9. Setting the Valve's Upper and Lower Limits	36
10. Setting the Auto Delay.	38
11. Stroking the Valve	39
12. PID Control Loop Tuning	41
13. Running the CentriFeeder™	42
Anti-Binding Function	45



14. Filling Mode Using an Auxiliary Feeder	46
15. Setting the Alarm - Rate	48
16. Setting the Alarm - Totalization	50
17. Setup of Remote Reset Capability	52
18. Using the Compact Flash	53
Removing the Flash Card	53
Remote Ethernet Access	55
Remote View	56
View Logs	56
19. Changing the IP Address	59
20. Example of Establishing Communication to PLC: ControlLogix Unit	61
21. Tag Mapping	62
SCREEN GUIDE	
22. Setup of Multiple Calibration	64
23. HMI Screen Guide	67
TOP	67
TOP.RUN	68
RUN.FILL	69
TOP.CAL	70
TOP.COM	71
TOP.SET	72
TOP.IO	73
CAL.ZERO	74
CAL.CALs	75
CAL.CALd	76
CAL.RANGE	77
CAL.INHIBIT	78
CAL.FILTER	79
CAL.EUNITS	80
SET.RATIO	81
SET.FIELD	82
SET.CALd	83
I/O.WCOUNT (Optional)	84
IO.ALARM	85
IO.ALARM.SP	86
IO.WEIGHT.OUT	87
ADV.PLC	88
REFERENCE	
24. Definition of Terms	89
25. Certificates	92



SAFETY

SAFE OPERATION

PLEASE READ BEFORE OPERATING THE CENTRIFLOW METER

- Only authorized personnel should operate Eastern Instruments equipment. Untrained personnel present a hazard to themselves and the equipment and improper operation will void the warranty.
- Check for damaged parts before operating the meter. Any damaged part should be properly repaired or replaced by trained personnel. Do not operate the meter if any component does not appear to be functioning correctly. Contact Eastern Instruments for assistance or for repair components.
- Use the appropriate Personal Protection Equipment as required for operating the meter within its installation location.
- The various surfaces of the equipment may have sharp edges and have the potential to cause injury. Use the proper protection for your hands when servicing or maintaining your equipment.
- The electrical panel (digital electronics) should be closed and the safety latch engaged at all times except during installation or service. At those times, only authorized personnel should have access to the electronics panel. When power is activated, AC voltage may be present throughout the panel. Therefore extreme caution is required.
- ◆ **DO NOT modify or alter this equipment in any way. If modifications are necessary, all such requests must be handled by Eastern Instruments. Any modification or alteration of any Eastern Instruments equipment could lead to personal injury and/or mechanical damage and will void the warranty.**

WARNINGS AND CAUTIONS

- Once power has been supplied to the equipment, it is always on and there is a potential that product may run through it at any time.
- Avoid entering or placing body parts within the equipment or its enclosure.
- Do not operate without proper training
- Always wear proper PPE
- NEVER service equipment while power is connected.

SAFETY PLACARDS

SOME OR ALL OF THESE WARNINGS MAY BE ON YOUR METER. BE AWARE OF THE POSSIBLE DANGERS PRESENT.



ELECTRICAL SERVICE

Electrical shock or electrocution is possible when servicing the electronics of any Eastern Instruments equipment. Be sure to disconnect power before conducting any repairs on the electronics.



PRODUCT FLOW

The Control Valve for the CentriFeeder is used only as a control valve and does not act as an isolation valve. A secondary isolation valve is recommended to be installed before the CentriFeeder's control valve in order to isolate the CentriFeeder from flow during maintenance or repairs.



PINCH POINTS

The control valve of the CentriFeeder can cause serious injury or amputation. Keep hands clear of the control valve at all times.



LIVE ELECTRICITY

Live electrical wires may be present. Please note that coming into contact with the live wires (AC Power) could cause electrical shock or electrocution.



INSTALLATION

INSTALLATION REQUIREMENTS

- The meter is to be used in a location where the product can be dropped from a fixed height such as a conveyor, or any type of feed system, which will give a reasonably constant initial vertical velocity. The design of the meter requires the product to contact the Tangential Plate and have some vertical drop.
- The meter should be installed so that it is level in two planes. Use the Bubble Level on top of the Seal Top to help.
- The meter should be mounted using the mount holes only. The mounting method should minimize vibration and any movement. Mounting should not be done using the flange(s).
- The discharge chute that the product stream empties into after traveling through the meter must be free flowing, meaning that it does not allow product to build up and consequently contact the Pan of the meter.
- The Electronics Enclosure and valve should be wired using only the factory cable. There is a standard 10' cable package that includes the Remote Electronics Cable, the valve Power Cable, and the Valve Position Sensor Cable supplied with the CentriFeeder™ Meter. The cables should be cut to the exact length required. Do not coil the cables.
- It is required that the Remote Electronics Cable be run through its own grounded metallic conduit connected on the side of the module and the bottom of the Electronics Enclosure. This Cable MUST be in a separate conduit than that of the AC Power or 24 Vdc Power supplied to the Electronics Enclosure. The valve power and position sensor signal cable can be together in their own grounded metallic conduit.

INSTALLATION TROUBLE AREAS

- The CentriFeeder™ Meter's 4-20mA signal is self-powered and does not require any additional voltage.
- DO NOT RUN 480V, 240V, OR 120V AND SIGNAL LINES IN THE SAME CONDUIT. The power and signal lines should be separate from each other and from all other devices. Running any other power or signal lines in the same conduit could affect the performance of your meter. Isolate both power and signal lines from each other at all times.
- The CentriFeeder™ Meter is balanced at a specific angle and should not be subject to vibration or movement. The mass of the mount should be at least 2 times the mass of the meter .
- The Seal Top should be on the meter at all times that you are not working inside the meter. This is to keep all foreign materials out of the meter that could obstruct its movement or impair its functionality.



Electronics Enclosure
Dimensional Drawing

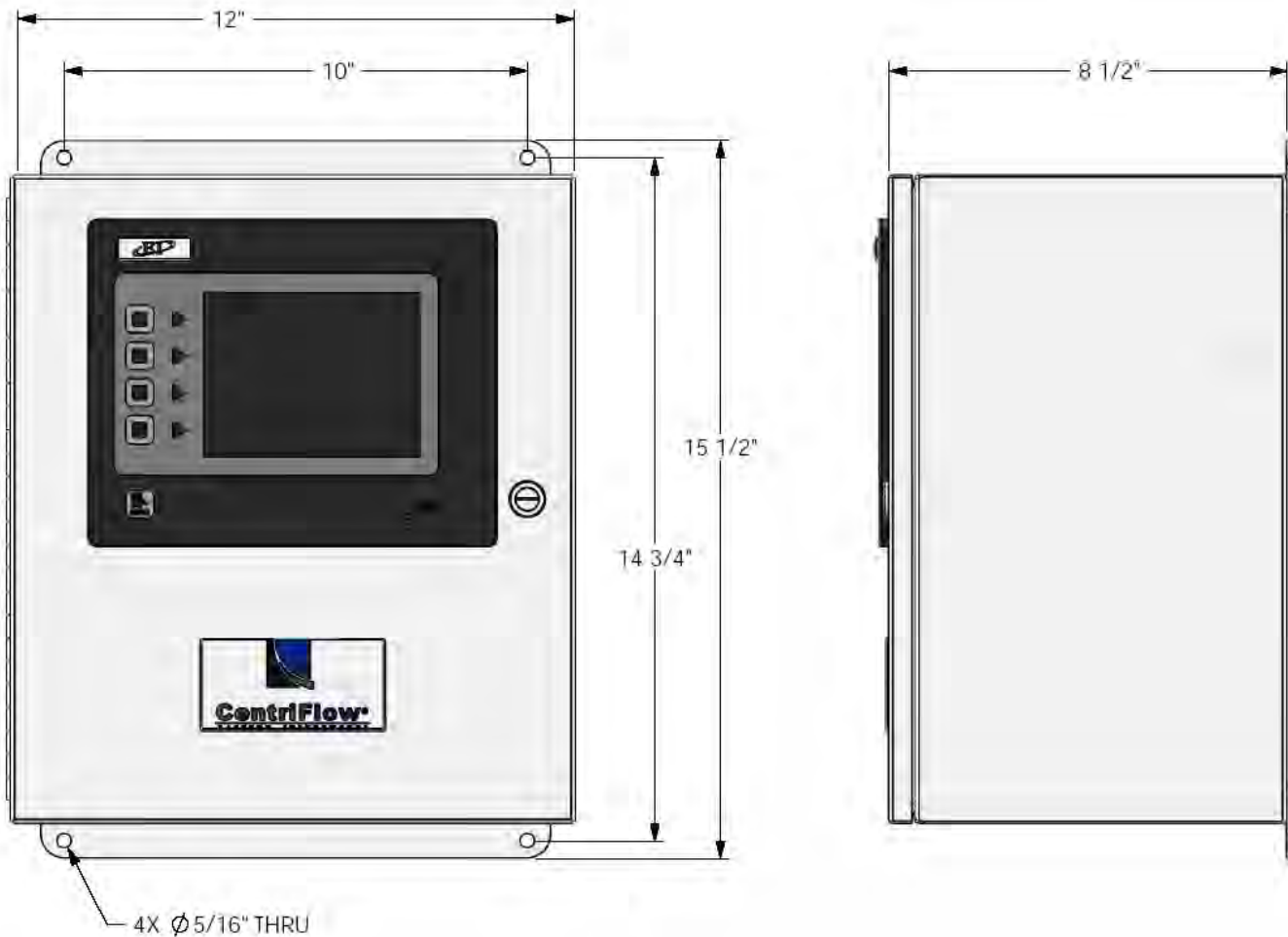



Identifying Your Components: Electronics

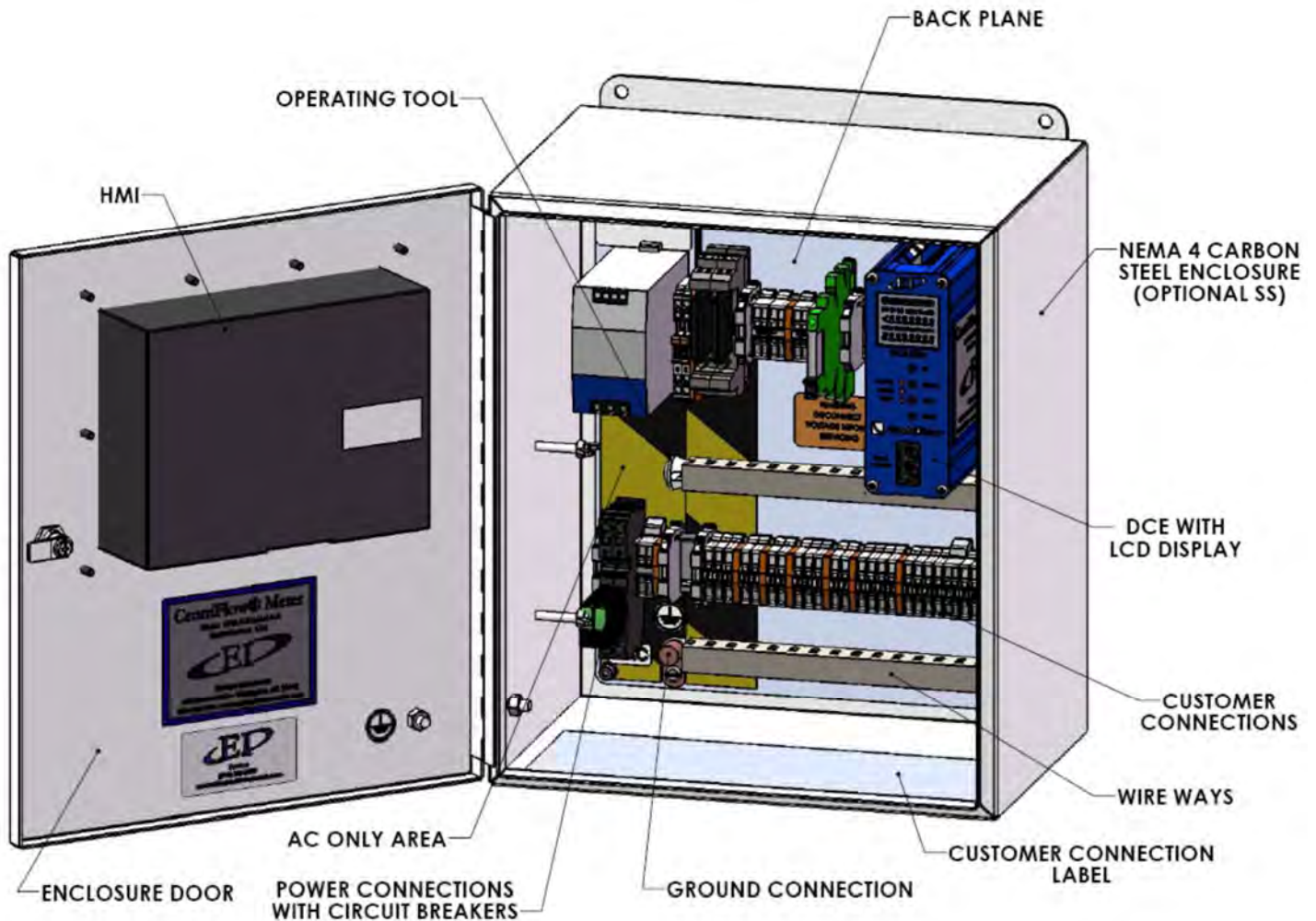

The Digital Electronics Enclosure contains the HMI, the Digital CentriFlow® Electronics (DCE), Power Supply, Alarm Relay, Power Connections with Knife Disconnects, and the Customer Connections.



Identifying Your Components: CentriFeeder with ICV

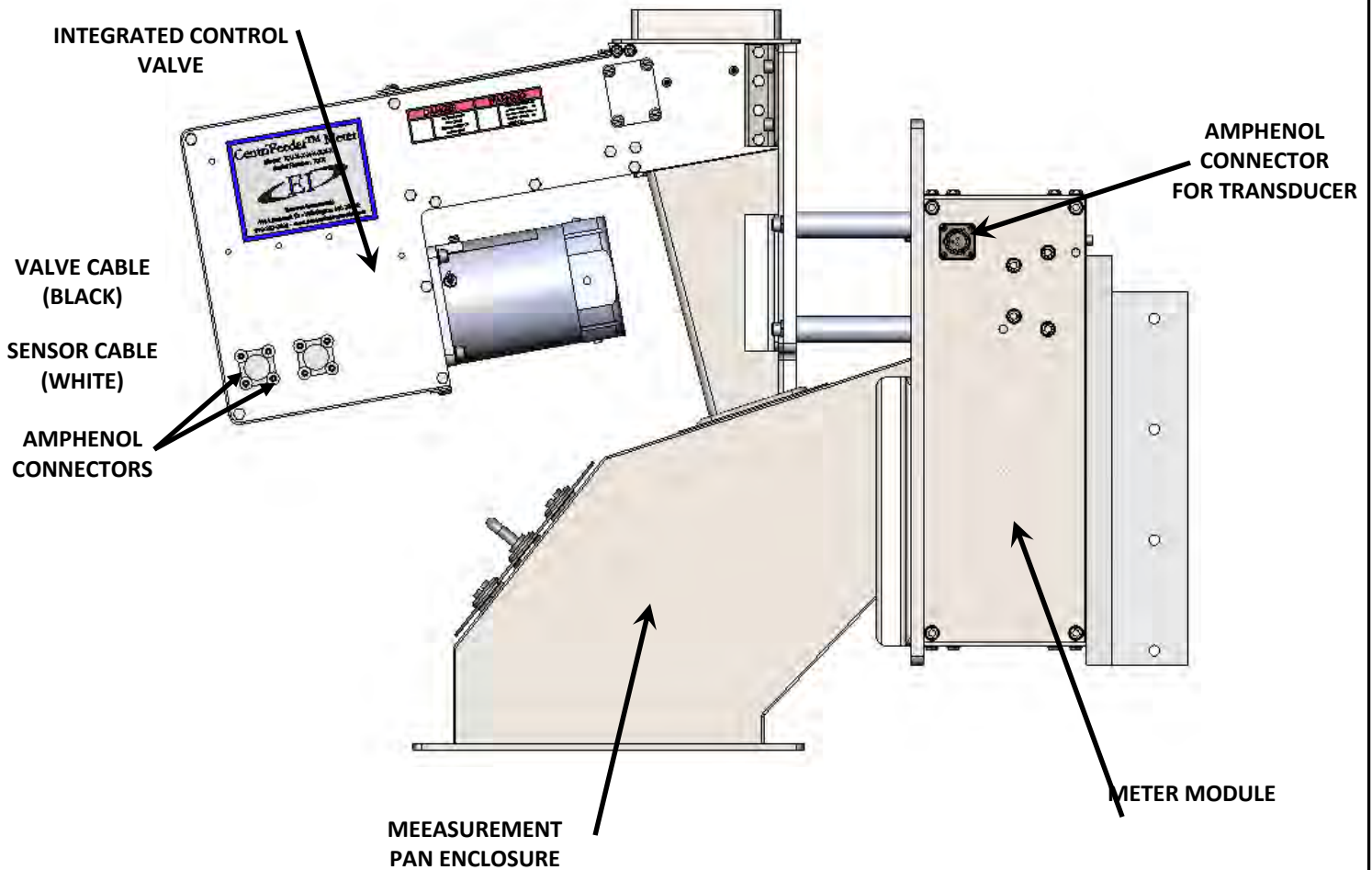

Please be sure to ground the Wago Connector for the Transducer. To do so, run your ground wire, along with the Transducer Cable, through the Customer Provided Conduit and Connect to both the Meter and The Digital Electronics as shown. The Ground Wire should attach to both the Ground Screw on the Wago Connector Mount (Above) as well as to the Ground Lug within your Digital Electronics (Right).

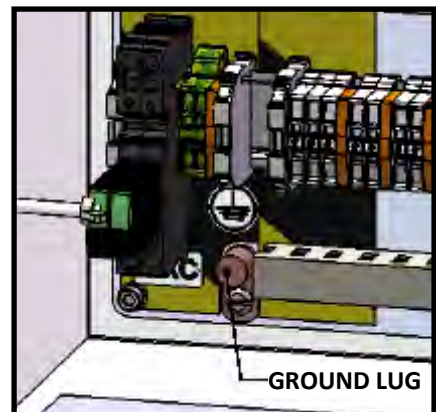



Identifying Your Components: Auxiliary Control

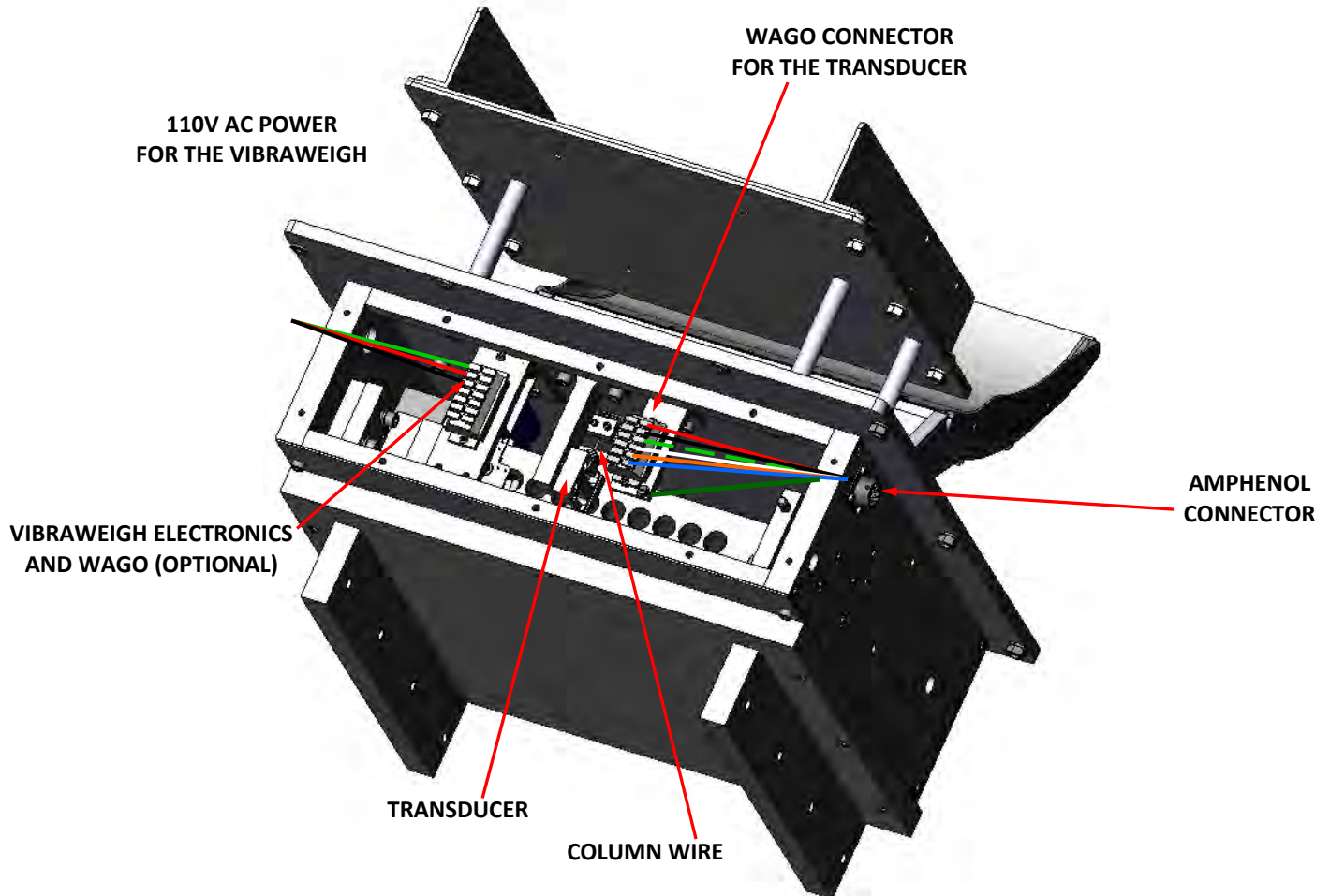

Please be sure to ground the Wago Connector for the Transducer. To do so, run your ground wire, along with the Remote Electronics Cable, through the Customer Provided Conduit and Connect to both the Meter and The Digital Electronics as shown. The Ground Wire should attach to both the Ground Screw on the Wago Connector Mount (Above) as well as to the Ground Lug within your Digital Electronics (Right). In the case of Digital Electronics Upgrades, if there is no green Ground Screw on the meter's Wago Connector Mount, attach the Ground Wire to one of the mounting screws for the Wago Connector itself.

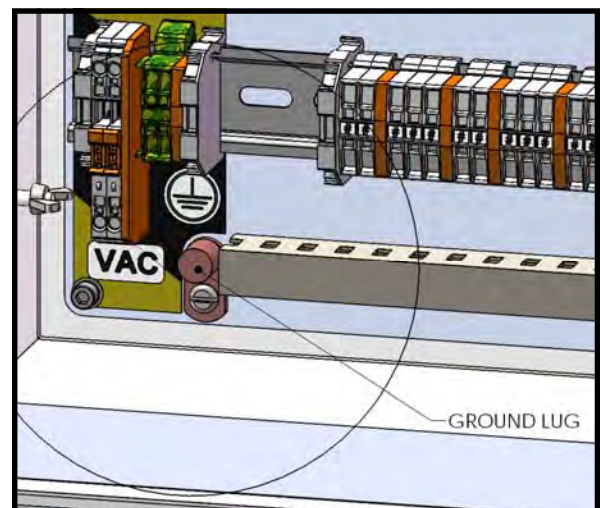

Basic Wiring:

Wiring of the CentriFeeder™ can be broken down to the following categories:

- Ground the CentriFeeder Module
- Wiring Electronics Cable at the Meter Module
- Wiring the Customer Connections at the Electronics Enclosure
- Connecting the Power

Electrical Information:

The following DCE digital signals are phototransistor outputs:

- Frequency, Flow Rate Proportional (Rate)

The Internal DCE Schematic to the right shows the Rate Output. However, all digital outputs are designed using the same circuit.

*Digital Output 1 and 2 share power and ground

**Digital Output 3 and 4 share power and ground

Digital Output	Function
DOUT1*	(Option)
DOUT2*	Alarm
DOUT3**	(Option)
DOUT4**	(Option)
RATE	Frequency, Flow Rate Proportional
COUNT	Weighted Count (Option)

Internal DCE Schematic

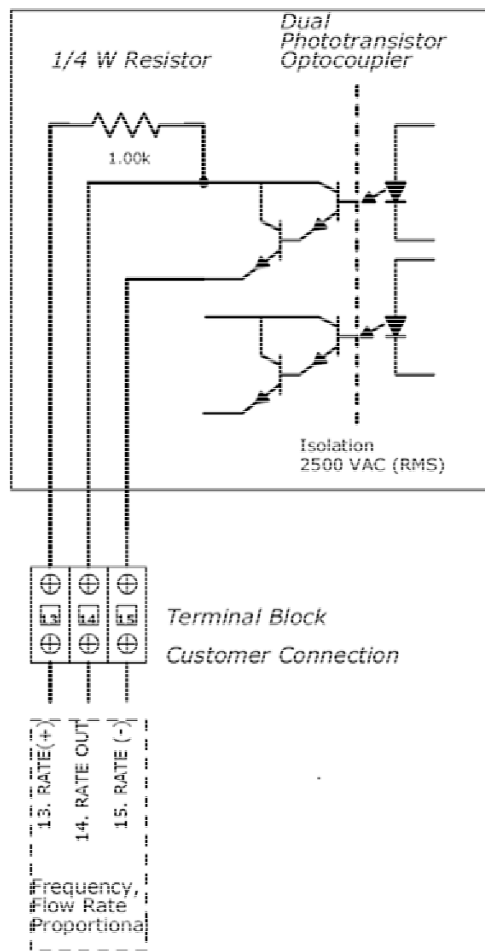

GROUNDING THE CENTRIFEEDER

A separate Earth Ground Wire (14 gauge) is required to be connected to the meter module. This ground wire is required for operator safety and for proper operation. This ground must be supplied from the main plant ground at the service entrance.

PLEASE BE SURE TO GROUND THE CENTRIFEEDER METER MODULE TO AN EARTH GROUND!



**CENTRIFEEDER WITH ICV:
WIRING THE REMOTE ELECTRONICS CABLE AT THE METER MODULE**

The Remote Electronics Cable is a 9 conductor cable with a shield that attaches the CentriFlow® Meter Module of your CentriFeeder to the Electronics Enclosure. It sends the measurement signal from the Transducer inside the Module to the Electronics Panel inside the Electronics Enclosure. The standard length is 10' long, but it should be cut to the exact length needed. If the distance from the CentriFlow® Meter Module to the Electronics Enclosure is more than 10', a custom length cable which may be supplied with the meter, should also be cut to fit. Excess cable should never be coiled up and placed into the CentriFeeder® Meter Module. One end of the Remote Electronics Cable will be affixed to the meter module, while the other end will be cut to length and will be wired to the Electronics Enclosure as demonstrated in the "Wiring the Digital Electronics" portion of this manual. PLEASE NOTE: The Electronics Cable MUST be run through grounded metallic conduit. If your Electronics Cable has an Amphenol Connector on one end, we would recommend leaving a short length of cable out of the conduit near the meter module and using a cable gland/wire grip type of connector on the end of the conduit.

WIRING THE METER MODULE - 9 CONDUCTOR CABLE:

One end of the Remote Electronics Cable will be affixed with a 10-pin Amphenol Connector. This end will be connected to the Meter Module Casing as shown in the picture below. The other end of the cable will be cut to length and will be wired to the Electronics Enclosure as demonstrated in the "Wiring the Digital Electronics" portion of this manual.

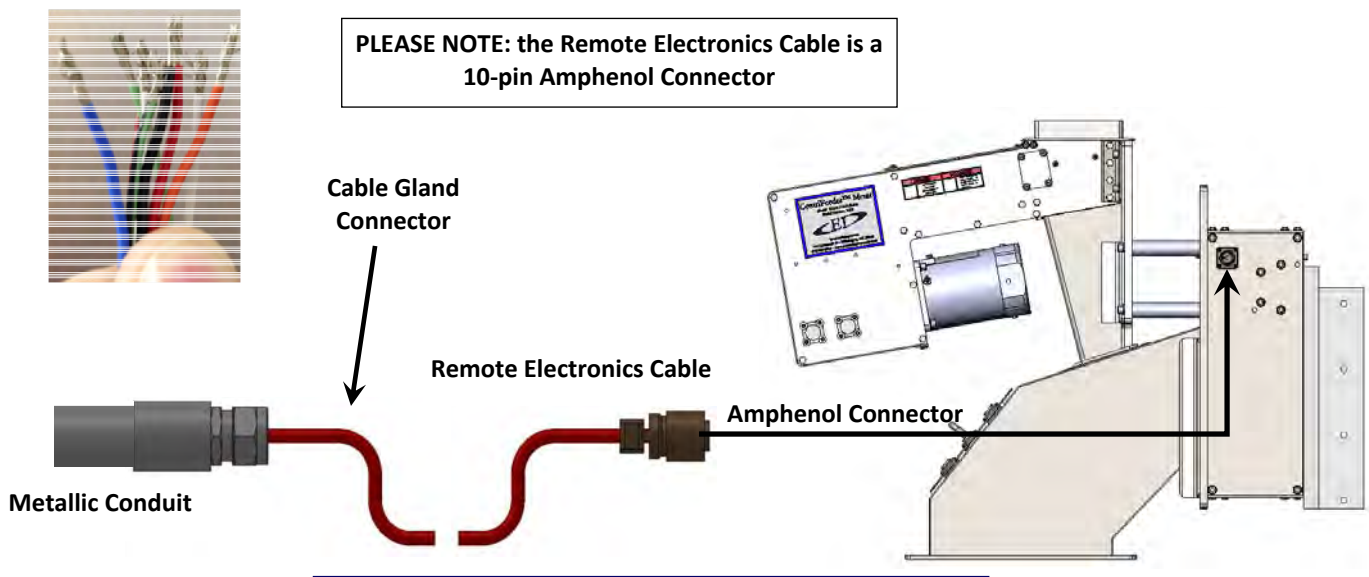

**CENTRIFEEDER WITH AUXILIARY CONTROL:
WIRING THE REMOTE ELECTRONICS CABLE AT THE METER MODULE**

The Remote Electronics Cable is a 9 conductor cable with a shield that attaches the CentriFlow® Meter Module to the Electronics Enclosure. It sends the measurement signal from the Transducer inside the Module to the Electronics Panel inside the Electronics Enclosure. The standard length is 10' long, but it should be cut to the exact length needed. If the distance from the CentriFlow® Meter Module to the Electronics Enclosure is more than 10', a custom length cable which may be supplied with the meter, should also be cut to fit. Excess cable should never be coiled up and placed into the CentriFlow® Meter Module. One end of the Remote Electronics Cable will be affixed to the meter module, while the other end will be cut to length and will be wired to the Electronics Enclosure as demonstrated in the "Wiring the Digital Electronics" portion of this manual.

PLEASE NOTE: The Electronics Cable MUST be run through grounded metallic conduit. If your Electronics Cable has an Amphenol Connector on one end, we would recommend leaving a short length of cable out of the conduit near the meter module and using a cable gland/wire grip type of connector on the end of the conduit. The Amphenol connector can be exposed without being inside the conduit.

WIRING THE METER MODULE - 9 CONDUCTOR CABLE:

One end of the Remote Electronics Cable will be affixed with a 10-pin Amphenol Connector. This end will be connected to the Meter Module Casing as shown in the picture below. The other end of the cable will be cut to length and will be wired to the Electronics Enclosure as demonstrated in the "Wiring the Digital Electronics" portion of this manual.

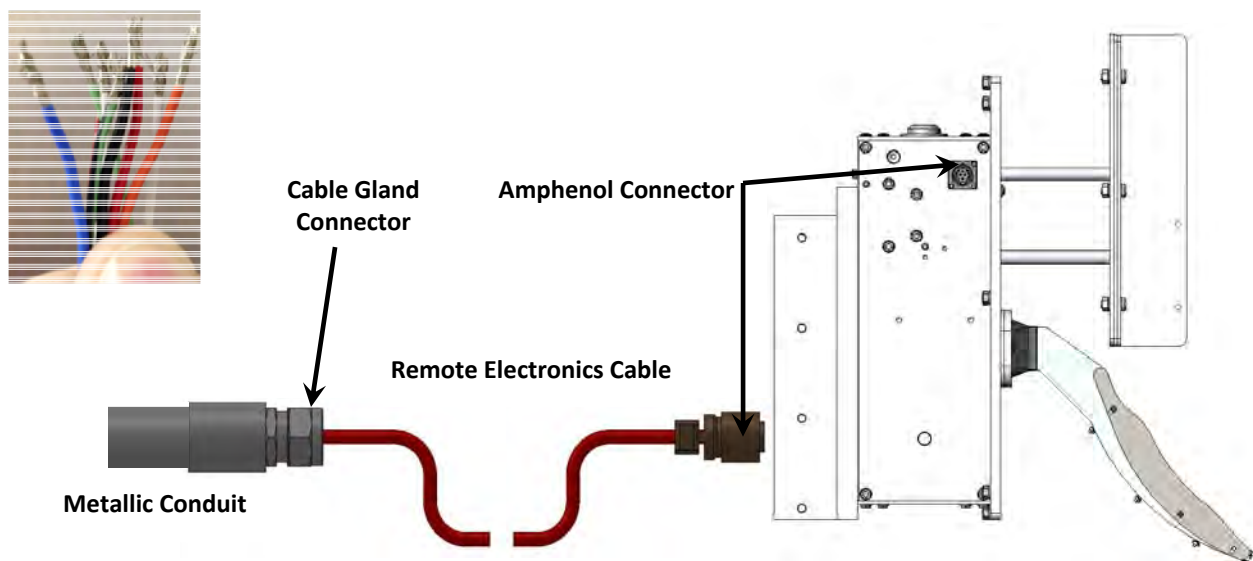



Wiring Customer Connections At the Electronics Enclosure

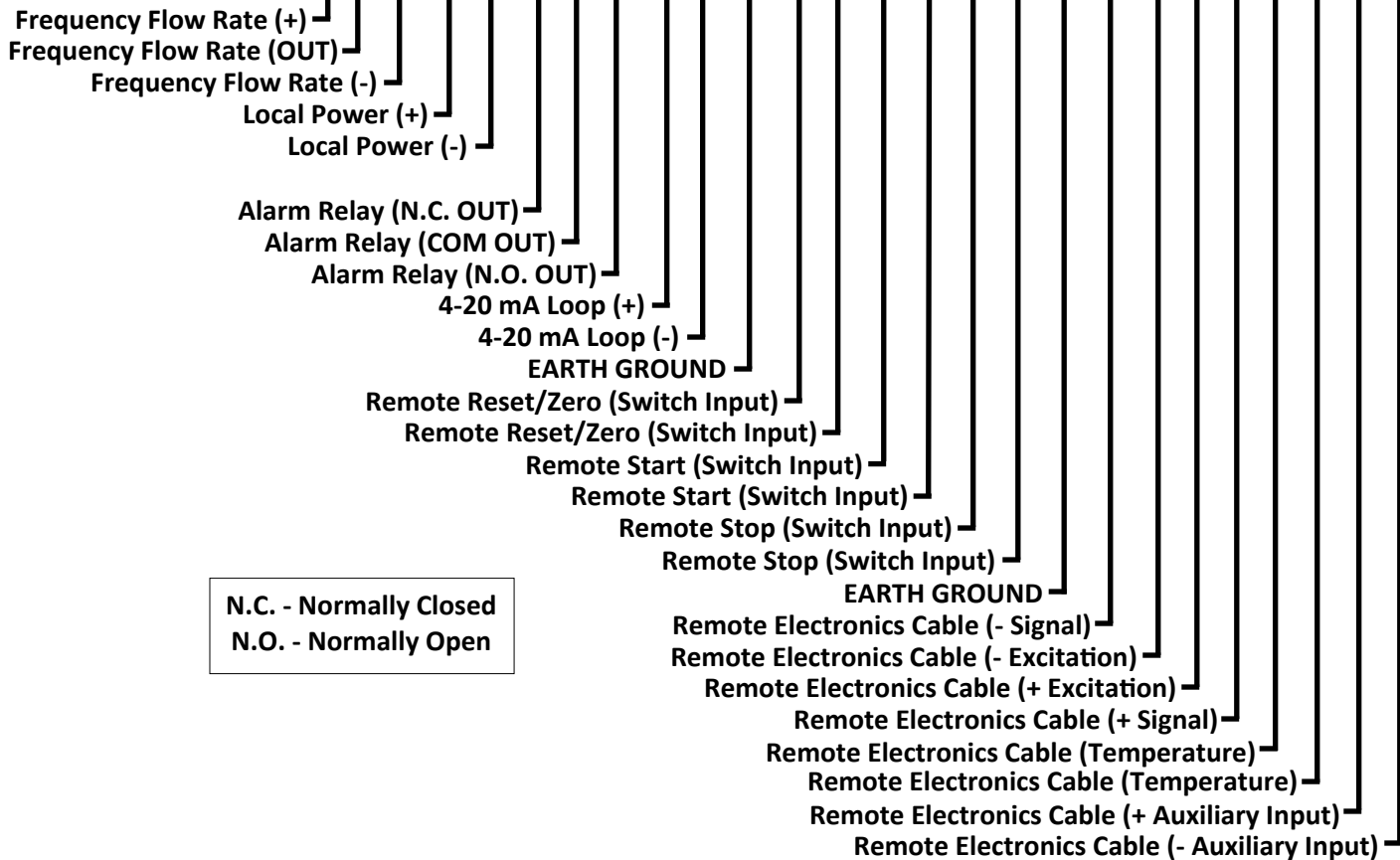
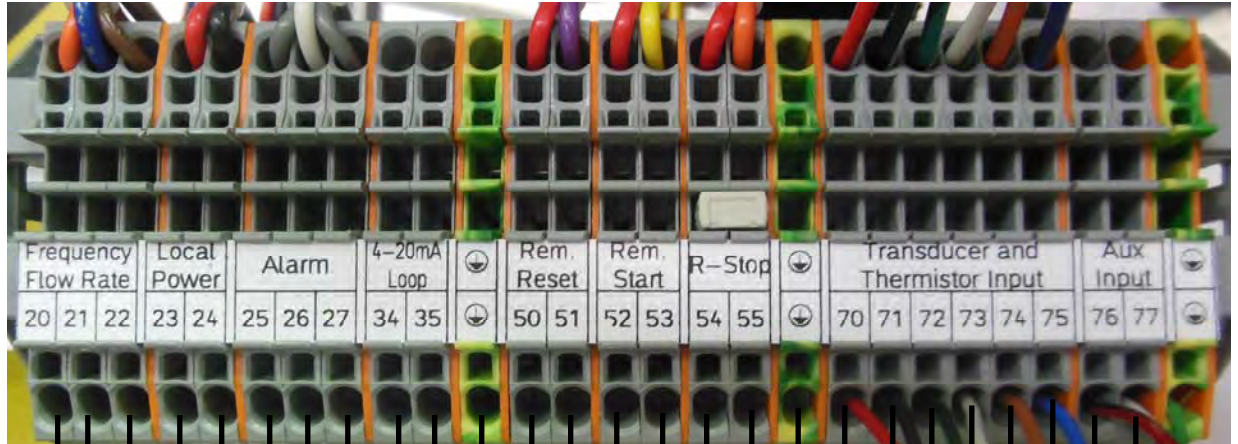

PLEASE NOTE THAT ADDITIONAL TERMINALS MAY BE PRESENT DEPENDING ON YOUR CENTRIFEEEDER'S CONFIGURATION. THE ADDITIONAL TERMINALS ARE DETAILED ON THE FOLLOWING PAGES.

**All Connections are made to the Bottom of the Terminal Blocks*

Start/Stop Control - Auxiliary Feeder only

You must properly wire your auxiliary controller using the connectors shown. For this step, the terminals are wired to the indicated terminal using the appropriate 18 gauge three conductor cable (not provided).

GRAY (Normally Closed)	-	#3 ICV Power
WHITE (Common)	-	#4 ICV Power
GRAY (Normally Open)	-	#5 ICV Power

Input Voltage	115 VAC
Input Current	5A
Input Frequency	47-63 Hz

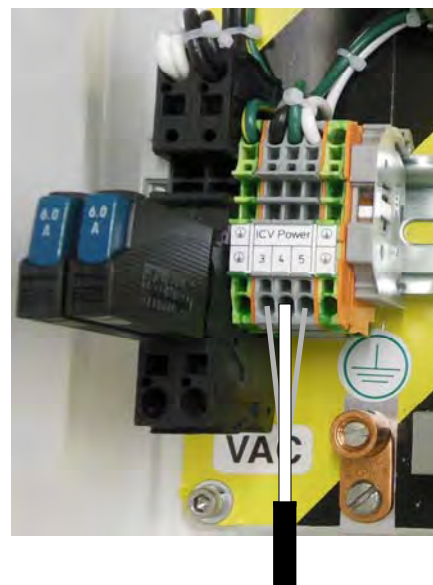

**All Connections are made to the Bottom of the Terminal Blocks*



Position Sensor - CentriFeeder with ICV only

White Cable

The Position Sensor allows the Digital Electronics to “sense” the position of the blade within the valve in order to determine how open or how closed it is. To wire the Position Sensor, use the White cable provided to wire the terminals on your **Customer Connections** to the corresponding terminal in your Integrated Control Valve as shown below:

- | | | |
|--------------------|---|---------------------|
| RED WIRE | - | #83 Position Sensor |
| WHITE or BLUE WIRE | - | #84 Position Sensor |
| BLACK WIRE | - | #85 Position Sensor |

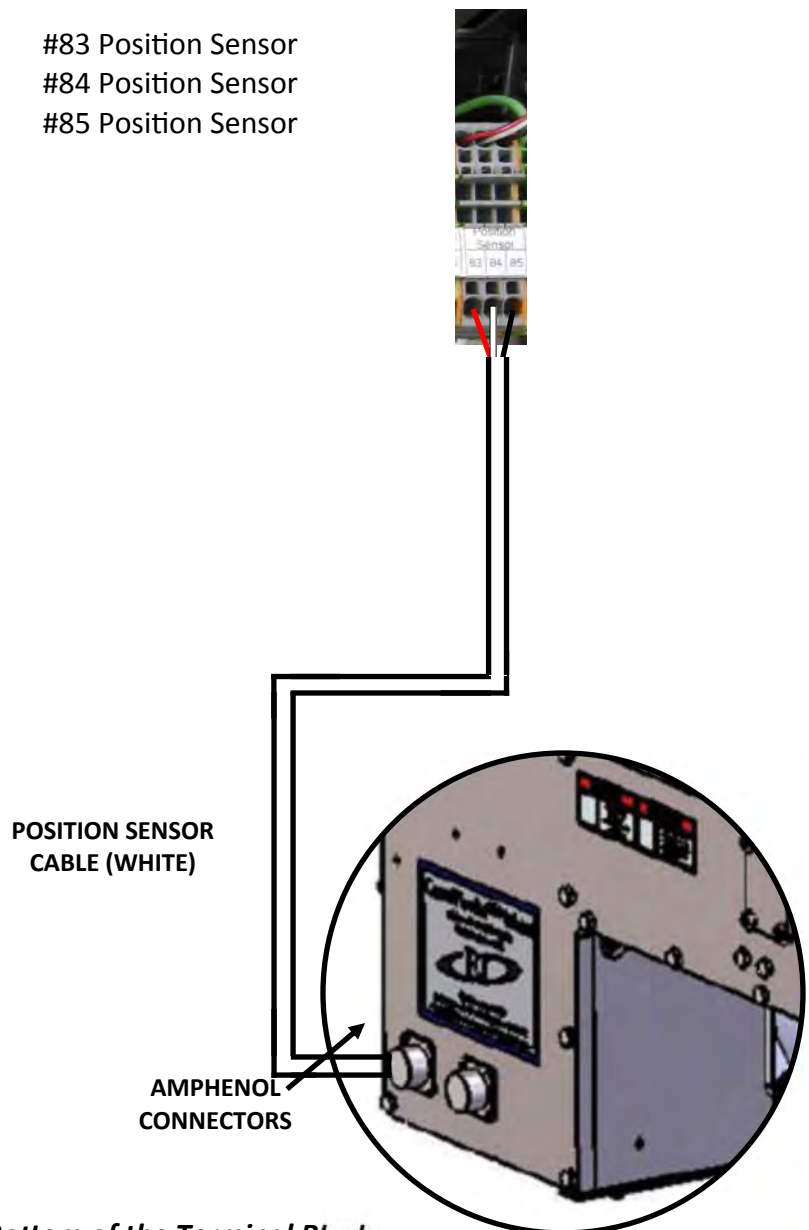

**All Connections are made to the Bottom of the Terminal Blocks*



Wiring the Remote Electronics Cable

When wiring the Remote Electronics Cable to your Digital Electronics Enclosure, please match the Customer Connections terminals inside your Digital Electronics to the picture below. If they are different please contact EI for further instructions. The table below shows the correct wire color and terminal for each type of Remote Electronics Cable available. Match your cable to the column in the table below and ensure that the appropriate wires are landed to the appropriate terminals.

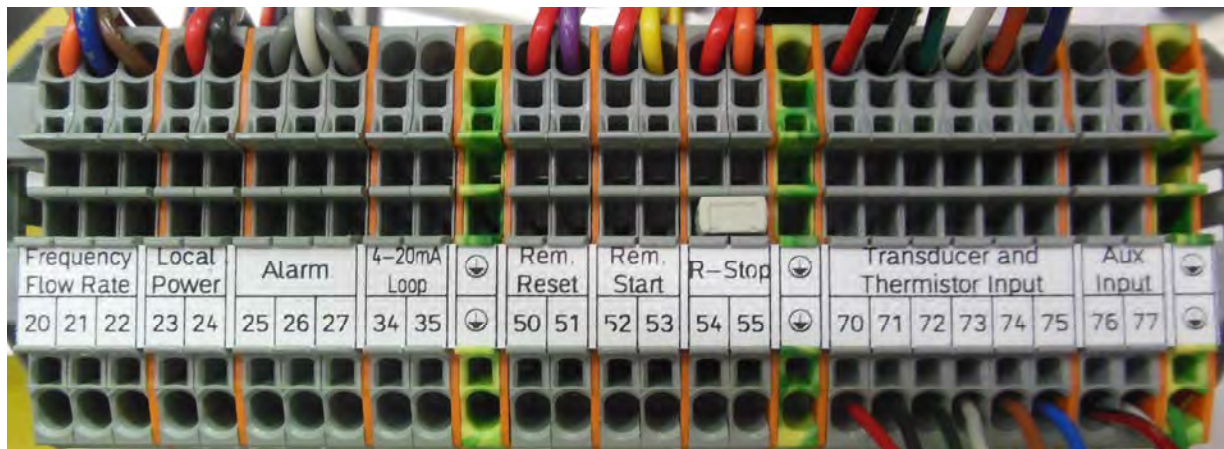

<i>Remote Electronics Cable</i>	<i>4 Conductor Cable</i>	<i>6 Conductor Cable</i>	<i>9 Conductor Cable</i>	<i>Landing Terminal</i>
Shield	Shield	Shield	N/A	Ground Terminal
- Signal	Red Wire	Red Wire	Red Wire	70
- Excitation	Black Wire	Black Wire	Black Wire	71
+ Excitation	Green Wire	Green Wire	Green/Black Wire	72
+ Signal	White Wire	White Wire	White Wire	73
Temperature	N/A	Gold Wire	Gold Wire	74
Temperature	N/A	Blue Wire	Blue Wire	75
+ Auxiliary Input	N/A	N/A	Red/Black Wire	76
- Auxiliary Input	N/A	N/A	White/Black Wire	77
Ground	Green or Green/Yellow Wire (Separate Wire)	Green or Green/Yellow Wire (Separate Wire)	Green Wire	Ground Terminal

Customer Connections Outputs

24V Local Power Output

For your convenience a 24 Volt Local Power Output has been provided that can be used to power the various outputs as listed above. Install a Jumper Wire from the positive terminal of the Local Power Output to the positive terminal of the desired output and a Jumper Wire from the negative terminal of the Local Power Output to the negative terminal of the desired outputs to provide power to the output.

Note: Use of local power will result in a loss of isolation.

4-20 mA Output

Analog Output (Sourced)

Loop Power NOT Required

Maximum Load Resistance = 900 ohms

NOT AVAILABLE FOR CENTRIFEEDER VIB

The CentriFlow® Meter Electronics is capable of outputting an analog signal. This signal is a 4-20 mA instantaneous isolated signal. The signal output is proportional to the Electronic Full Scale Flow Rate. For example, if the Electronic Full Scale Flow Rate were calibrated to be 300 lb./min, then an output of 12 mA would correspond to a Flow Rate of $(12-4)/(20-4) \times 300 = 150$ lb./min or 50% of the Electronic Full Scale Flow Rate. Since this output is directly related to the Electronic Full Scale Flow Rate any change in Calibration to change the Electronic Full Scale Flow Rate would result in a change in the signal so as to retain the proportionality. Thus, if the Electronic Full Scale Flow Rate were changed from 300 lb./min to 500 lb./min, then a 20 mA output would correspond to the 500 lb./min flow rate. Connection to this output signal will be made according to the CUSTOMER CONNECTIONS diagram below. It is recommended that the wires for this signal be routed through the conduit housing the power connection. It is recommended that this analog output be used for Control purposes and not for Trending unless a signal filter is used. Please see the filtering section of this manual for more details on filtering.

Alarm Output

Relay Output

The relay can be used to trigger alarms which warn the operator that a batch is complete or that the flow rate has exceeded a threshold. The output is programmable to be assigned for rate or count. When assigned to the count, the relay can have a user selectable on time (duration) or can be latched until reset.

Frequency, Flow Rate Proportional (Rate)

Digital Output Power Required

The CentriFlow® Meter Electronics is capable of outputting a Totalizing Pulse Output signal. The Frequency, Flow Rate Proportional signal is a pulse signal and is labeled "Rate" at the CUSTOMER CONNECTION block. The frequency of the signal is 0 to 500 pulses per second. The Rate +, supplied by the customer can be between 12 and 24 Volts. The Rate - is connected to the Common or Power Supply Ground. By connecting the Rate + and Rate - with customer supplied power and ground, the Rate Out signal will be isolated from the Digital Electronics. Although the preferred method of supplying power to the Rate output is customer supplied power, +24V local power is also available. Using the local power, however, results in a loss of isolation.

This Totalizing Pulse Output will output a Voltage Pulse that is related to the Electronic Full Scale Flow Rate. For example, if the Electronic Full Scale Flow Rate were calibrated to be 300 lb./min, then a flow rate of 150 lb./min would correspond to a pulse of 250, or 50% of Electronic Full Scale Flow Rate.

Remote Reset/Zero

Digital Input Pushbutton Switch

By installing a push button on/off switch or other mechanical relay contact, the Remote Input can be used to remotely reset your count. In order for this option to be utilized the push button on/off switch or other mechanical relay contacts (customer supplied) must be installed using the connection listed below. Please note that these inputs are prewired with voltage and only require contact closures to operate correctly (Wiring an SSR to this input will not work properly).



Pulsed Air (Optional)

If your CentriFeeder™ is equipped with a Pulsed Blast System, you will need to supply power to the solenoid valve on the side of the meter. Using at least an 18 Gauge, 3 Conductor Cable (not provided) connect the solenoid to the CentriFeeder™ Customer Connections as shown.

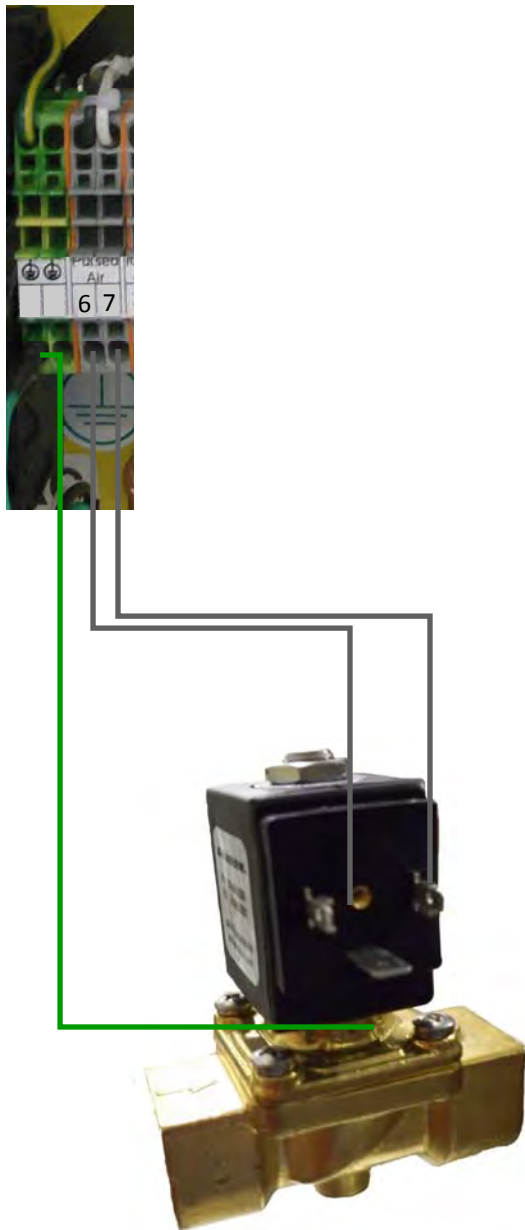

*Full Wiring
Diagram in
back.

All Connections are made to the Bottom of the Terminal Blocks

Power - Electronics Enclosure

The Digital Electronics Package includes a Power Supply to convert the customer provided VAC power to 24Vdc. Please see the diagram below for wiring connections.

WARNING: TURN POWER OFF AT SUPPLY CIRCUIT BREAKER BEFORE WIRING THE POWER TO YOUR DIGITAL ELECTRONICS PACKAGE!

VAC **ONLY** can be connected to the Power terminals illustrated below. The VAC power is then converted to 24 Vdc through the factory wired Power Supply to supply 24 Vdc power to the electronics.

Wire the VAC Neutral and VAC Line connections to the terminal blocks using the tool provided. The wiring connections are as follows:

- AC Ground - G (Green)
- VAC Neutral - N (White/Yellow)
- VAC Line - L (Black)

Input Voltage 115 VAC
 Input Current 5A
 Input Frequency 47-63 Hz

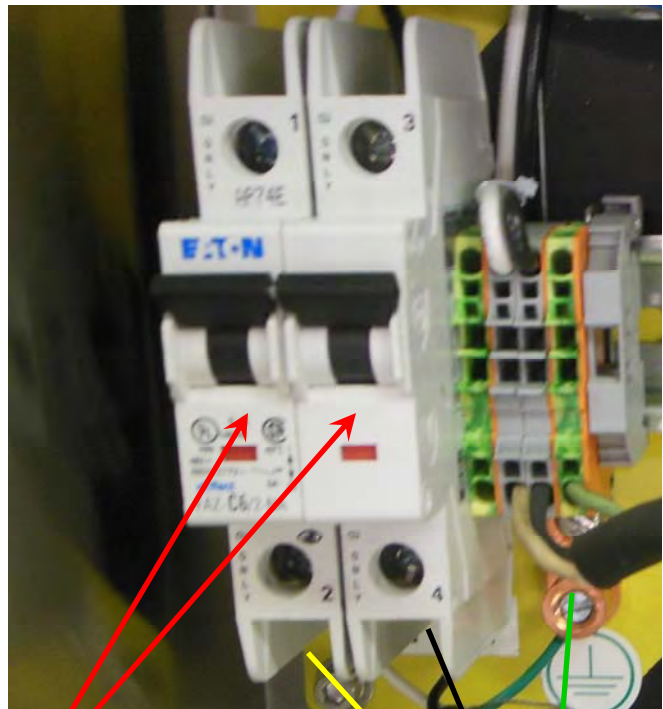

Circuit Breakers

All Connections are made to the Bottom of the Terminal Blocks



Power ICV Control Valve - CentriFeeder with ICV only

Black Cable

Power must be applied to the ICV in order to allow for movement of the ICV to both open and close. To wire the Power Cord for the ICV Control Valve, use the Black cable provided to wire the terminals on your **Customer Connections** to the corresponding terminal in your Integrated Control Valve as shown below:

BLACK WIRE	-	#3 COMMON
BROWN WIRE	-	#4 OPEN
RED WIRE	-	#5 CLOSE



POWER CABLE
(BLACK)

AMPHENOL
CONNECTORS

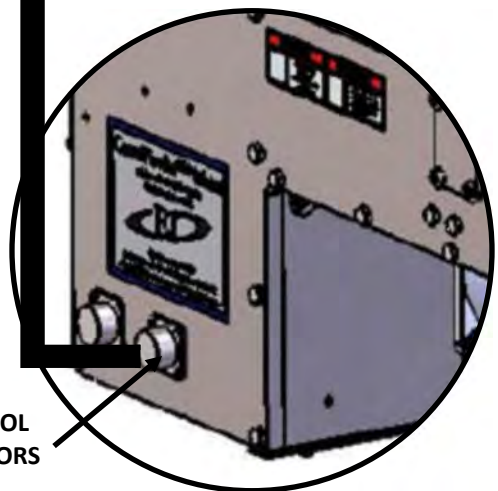

**All Connections are made to the Bottom of the Terminal Blocks*



Pulse Blast System (Optional)

If the CentriFlow[®] Meter was shipped with the Pulse Blast option please continue with the following directions.

PURPOSE:

The Pulse Blast System was designed to deliver a pulsed blast of air to the area in front of the Backplate and behind the Tangential Cover. The use of this air is intended to aid in reducing product buildup on the Pan Arms, behind the Tangential Plate. The blast of dry air should reduce buildup and greatly reduce miscalculations caused by buildup behind the Pan without adversely affecting measurement readings.

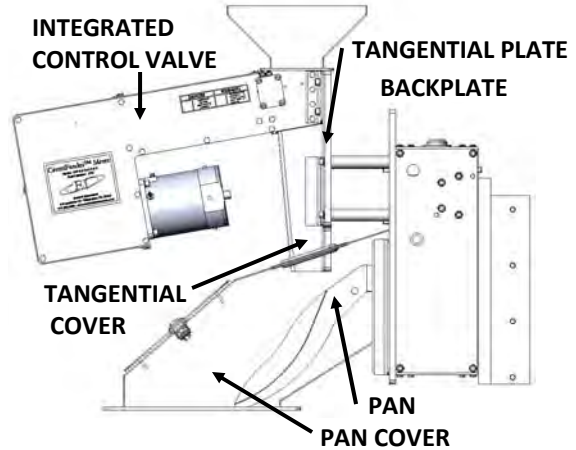

REQUIREMENTS:

- Included Components:**
- Pulse Blast Manifold
 - Pulsed Blast Air Chamber
 - Pressure Regulator & Gauge

- Also Required, Not Supplied:**
- ✦ Air Tubing (Metal or Plastic – see below)
 - ✦ Air Fittings with 1/4" NPT thread
 - ✦ Pipe Tape

COMPRESSED AIR LINE SIZES:

All tubing should be Stainless Steel 3/4" Schedule 40 NPT whenever possible.



REGULATOR
1/4" FNPT
SCH 40
PIPE THREAD

DRAIN VALVE
1/4" MNPT
SCH 40
PIPE THREAD

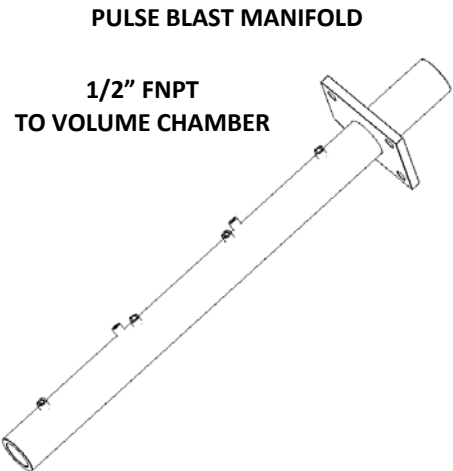



INSTALLATION DIRECTIONS

1. Install the Pulse Blast Manifold into the CentriFeeder™ Pan Cover so that the Flange on the Pulse Blast Manifold lines up with the Cut Out on the Pan Cover. If the meter was shipped with the Pulsed Blast System, the Pulse Blast Manifold will already be installed.
2. Mount the Pulsed Blast Volume Chamber to the Pulse Blast Manifold by connecting the 1/2" Male Pipe Thread Connection on the Volume Chamber to the 1/2" Female Pipe Thread Connection on the Pulse Blast Manifold. If the meter was shipped with the Pulsed Blast System, the Pulse Blast Volume Chamber will already be installed.
3. Connect an air supply to your Pulse Blast System by tubing the regulator with clean dry instrument air of at least 100 psig (689.5 KPa). The inlet line can be ¼" tubing. Flow capacity of the line is not critical since only one "blast" is used per start for the system.
4. Run a power cable between the solenoid valve and the CFM Electronics. The normal operation of the solenoid valve is 120 VAC at 15V, but it can be equipped with a 240 V coil for use in areas where 120 VAC is not available. The valve is powered by the CentriFeeder's electronics and does not need outside power, however a power cord to connect the solenoid valve to your digital electronics is required. The cord should be at least 18 Gauge, 3 Conductor Cable. Please see local requirements for whether Conduit or SO Cable is required. For normal use, do not exceed 250 ft of cable between the solenoid valve and your electronics enclosure.

OPERATION

1. Set the lowest Pulse Blast Time or duration of the Pulse Blast. The default value is 1/10 of a second and the maximum recommended is 3/10 of a second. The Pulse Blast Time is set on the ADV.BLAST page on your HMI. This page is accessed by pressing the Pulse Blast Button on the TOP.ADV page after pressing the ADV Button on the Main Menu.
2. Use the factory default pressure of 60 psig (413.7 KPa) to start. The pulse blast operates with the initiation of a "start" from either local or PLC control. At the end of the Pulse Blast Time, the ICV (Integral Control Valve) is activated in a normal start sequence. The sequence resets after a stop command.
3. Reduce the pressure on the regulator to the lowest pressure that will still ensure the proper cleaning of the measurement area. The lower the value of the pressure, the longer the life of the solenoid valve.

MAINTENANCE

1. Periodically check the operation by observing the pressure gauge located on the regulator. It will drop to ½ or more of the set pressure during the blast. If the pressure drop is not observed as the associated LED in the control box is lighting, then replace/clean the solenoid valve.
2. Drain the water from the Volume Chamber periodically until some pattern is established. If water is consistently found, consider adding an automatic drain to the volume chamber or improving the supply air quality. DO NOT allow water to fill the volume chamber and then spray into the meter measurement section.



A Closer Look at Your HMI

The main components of your HMI Touch Screen will be the Touch Screen itself, the LED Display, the Menu Soft-Key, and Soft-Keys 1 thru 4. By pressing the Menu Soft-Key, you will be returned to the Main Menu, or TOP page. The LED Display will give you information on your process, the status of your Compact Flash Card and on the status of any alarms that have been activated. Below is a detailed description of the LED Display.

LED DISPLAY CHART

LED	ACTIVITY	INDICATION
RED (TOP)		
	FLASHING	Unit is in the boot loader, no valid configuration is loaded
	STEADY	Unit is powered and running an application
YELLOW (MIDDLE)		
	OFF	No Compact Flash is present
	STEADY	Valid Compact Flash card is present
	FLASHING RAPIDLY	Compact Flash card is being checked
	FLICKERING	Unit is writing to the Compact Flash, either because it is storing data, or because the PC connected via the USB port has locked the drive
	FLASHING SLOWLY	Incorrectly formatted Compact Flash card is present
GREEN (BOTTOM)		
	FLASHING	A tag is in an alarm state
	STEADY	Valid configuration is loaded and there is no alarm present

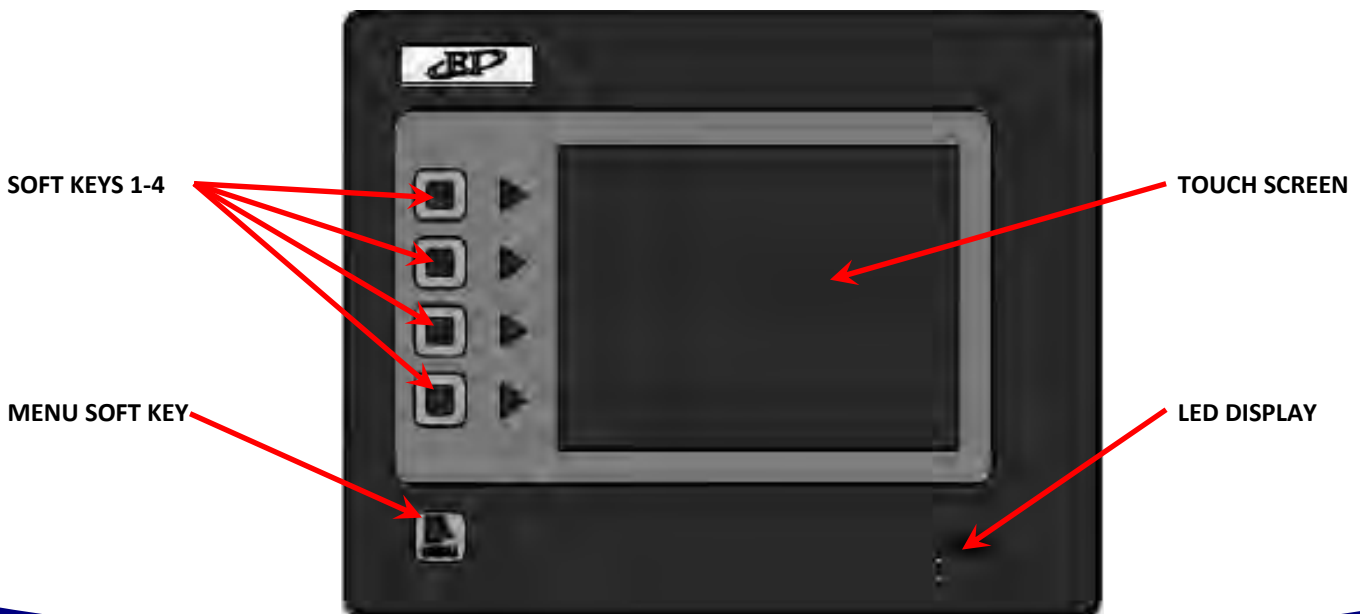



Powering On

To power on your digital electronics, open the Digital Electronics Enclosure and depress the breaker pushbuttons located on the VAC Power wiring connections as shown below.

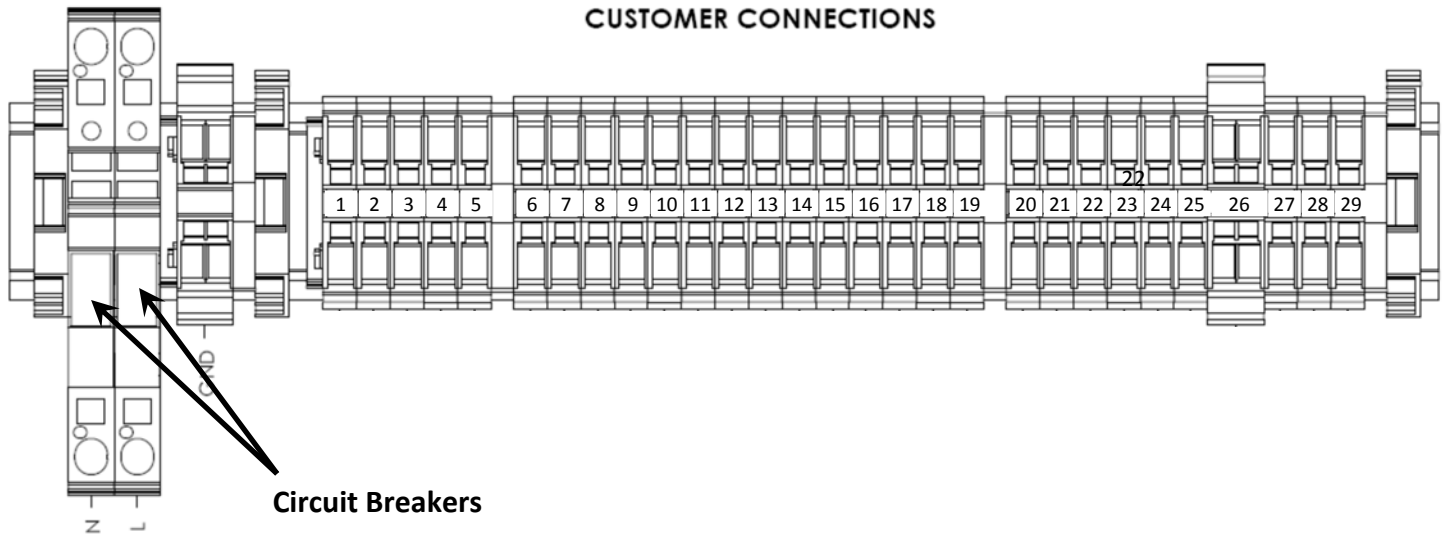

Close the Digital Electronics Enclosure. The HMI should now be coming on. Upon startup, the HMI will display the Main Menu Screen, also called TOP, as shown below.

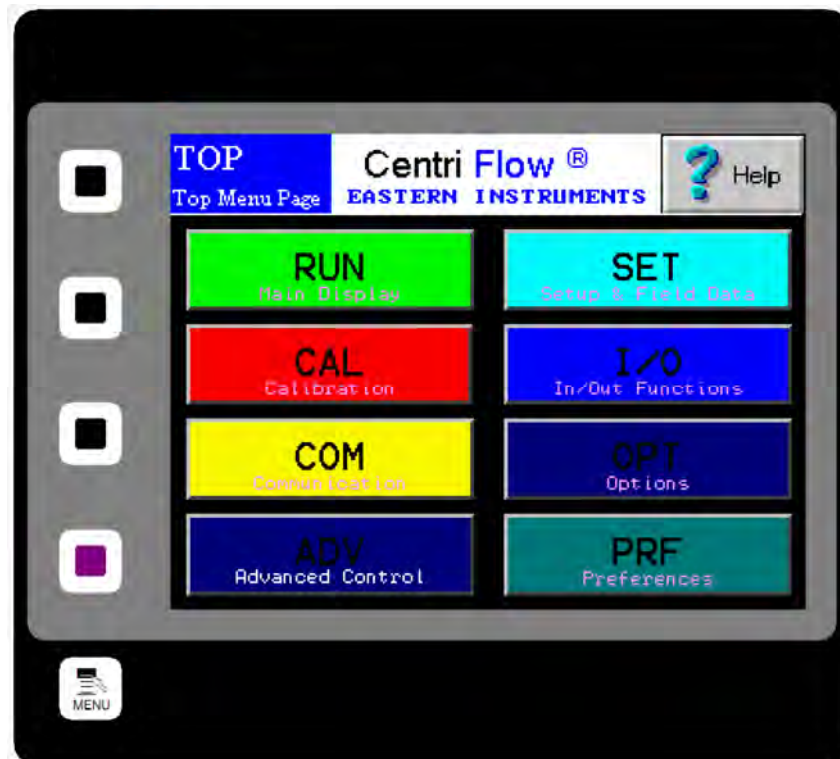



If the menu page is left undisturbed for several minutes the page will automatically switch to the TOP.Run page seen below:

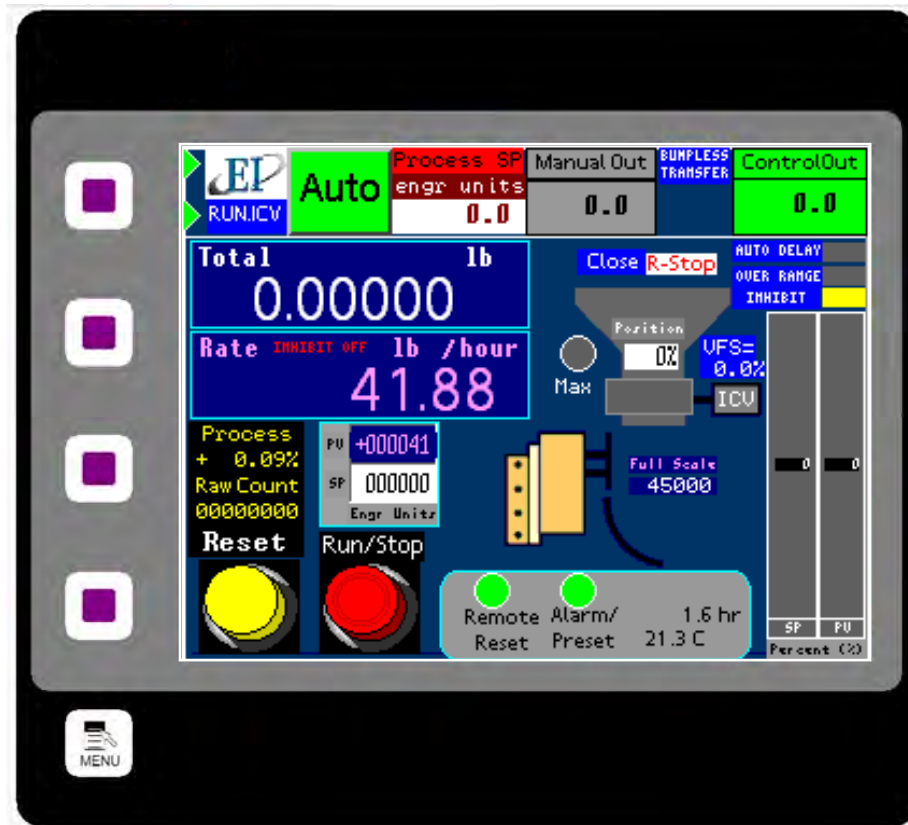

For more information on both the TOP page and the TOP.RUN page please see the HMI Screen Guide within this manual.

Security Features

Your CentriFlow® HMI is equipped with a security system that allows sensitive information and settings for your process to be protected via a password-based security layer. The password-based security system is designed to protect your information and settings from unauthorized access and tampering.

Please note that three pages require no security authorization to view. These pages are the TOP Menu, the TOP.RUN (or Main Display) page and the RUN.TREND (Plotting) page. All other pages require the entry of both a username and password to access.

Logging On

When accessing any page other than the three mentioned above, an orange “SECURITY MANAGER” dialog box will appear. Press the RETURN button to enter your username. Enter your username into the security dialog box, and press the Enter Button. You can then, enter your password into the security dialog box and press the Enter Button.

Please note that a default username and password have been entered. The default username and password are listed below:

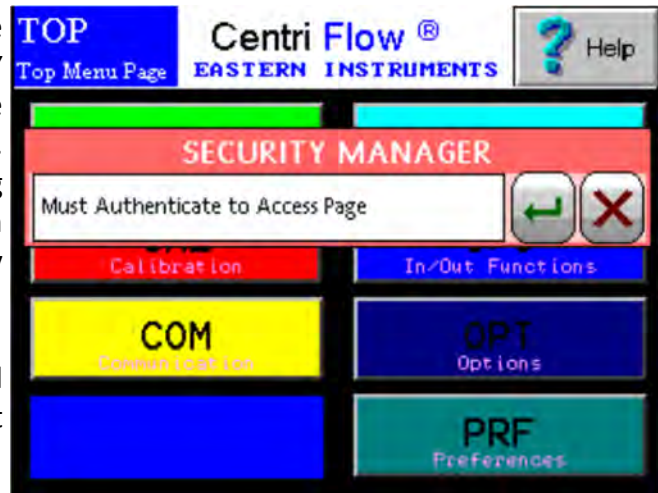

Username: **admin**

Password: **345**



After correctly entering your username and password, you will be logged on to the system. Please note that the HMI security system is configured to time out after 10 minutes of inactivity, at which time you will be required to login again. You will also be required to login any time the HMI unit is powered up.

Changing Your Password

The password-based security system of your HMI was designed to have a similar look and feel to computer-based security systems commonly encountered on a PC. It is recommended to change your password for security purposes, upon entering your system, however it is important to remember your password and to write it down and store it in a secure place, as once the password has been changed, the new password is required to operate the Centri-Flow® HMI.

From the Top Menu Page, Click the "Preferences" button. You will now be on the TOP.PRF (Preferences) page (seen on right). Click on the "Security Settings" button to go to the PRF.PASSWORD.SETUP page. Click "SET PASS" to change the Admin password. The "ENTER NEW PASSWORD" dialog box (shown below) will appear. You may now type in the new password. Again, you may click the "Symbol" button to use numeric characters. You will then be prompted to repeat the new password. The password should now be successfully changed.

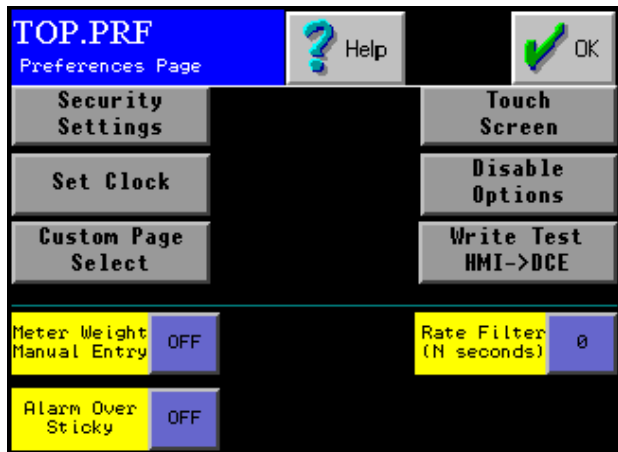

PROCEDURES

Static Calibration (Static Cal.)

Static Calibration sets the Range of the Transducer in the CentriFeeder™ Meter. This allows the meter to be versatile in a way such that it can be ranged up, known as Extended Static Calibration, or it can be ranged down, known as Reduced Static Calibration. The Static Calibration is a Factory Setting and should not need to be changed while the meter is in service, unless the Transducer has been replaced. Setting or checking the Static Calibration consists of two steps – Zero and Static Calibration. Note that readings are measured using two different units - %PV and % Volts. The difference between the two scales is the Dynamic CAL multiplier. The nominal value is five (5), this value equates to multiplying by one.

Before beginning the calibrations, make sure that there is no product on the Pan or around the Pan Arms.

The procedure for setting or checking the Static Calibration is as follows:

Step 1: Click the CAL Button on the TOP Menu, then click the ZERO Button.

Step 2: You should now be on the CAL.ZERO page as seen below.

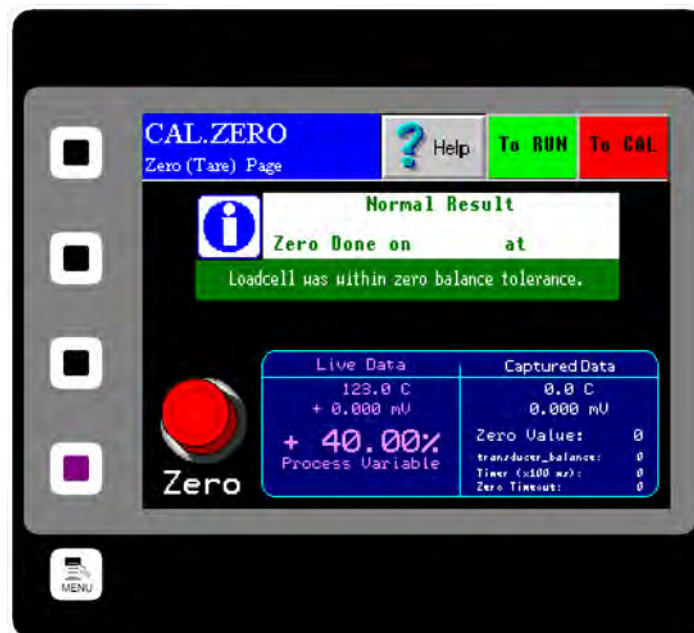

Step 3: Press the Zero Button. Verify that the number displayed in the Diagnostic Window is 0.0 % Process Variable.

Step 4: The Zero portion of Static Calibration is complete. Press the Red TO CAL Button on the upper right of the screen in order to return to the TOP.CAL page.

Step 5: Press the CALs Button. You should now be on the CAL.CALs page as seen on the next page.

Step 6: Hang the Test Weight provided with the Electronics Enclosure from the Calibration Stud located under the bottom edge of the Pan as seen below. For Pans that have more than one Calibration Stud, there should be a Test Weight for each. Some optional pans may not have a Stud. In these cases the wire will be long enough to hook onto the top edge of the pan and be draped over the front end of the pan as shown below. Be sure that the Test Weight hangs freely from the Calibration Stud. It is also good practice to allow the Test Weight to become stable and movement free before proceeding.

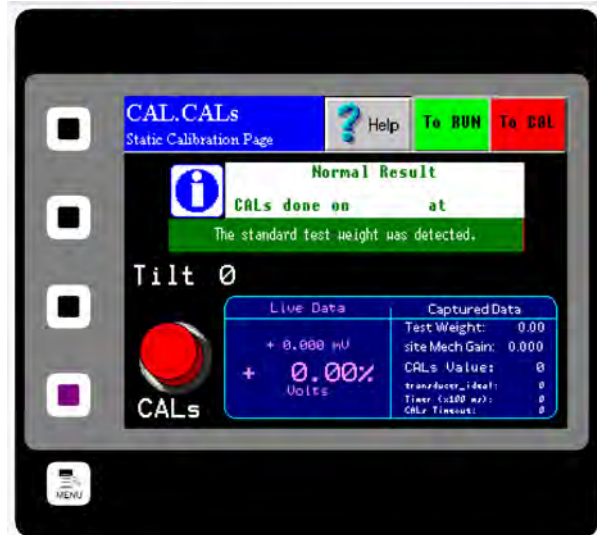

Step 7: Press the CALs Button located on the lower left side of the screen. Note the % Volts reading displayed in the Diagnostic Window. Verify the reading is correct for the selected range. For example, 25% is the correct value for the Standard Range setting. Please see the table below for the correct % Volts reading for each range.

Range	Extended	Standard	Reduced	Minimum
% Volts	12.5%	25.0%	50.0%	100.0%

Step 8: Remove the Test Weight from the Calibration Stud. The voltage should return to 0.00% Volts.





Site Calibration

When the CentriFeeder™ Meter is sent from the Factory it is set with Default values for the Static Calibration and the Calibration Voltage, which were chosen for the particular material being measured with the meter. As described in the previous Section, the Static Calibration is an adjustment that ranges the Transducer, the Measurement Element of the meter. This Setting will not change unless the Electronic Full Scale is changed.

The Calibration Voltage, however, is the adjustment that is made to Calibrate or Site Calibrate the Electronics to a particular application. Although the Factory setting may be quite accurate, it is likely due to differences in installation, feed systems, and material being measured, that an adjustment be made after the CentriFeeder™ Meter is installed. This procedure is very simple and will require a means of capturing material that is run through the meter and weighing that material. The closer the capture point is to the end of the Pan Section of the meter the less likely that there will be loss in the measurement sample and therefore less likely that there will be an error in the Calibration of the Electronics. It is important not to come in contact with the Pan Section when capturing the measurement sample so that the Electronics does not give incorrect results from measuring the contact. Always remember to fully secure the door back to the enclosure before resuming normal flow through the meter.

When performing the Site Calibration, it is recommended that a minimum of five samples be taken before making any Adjustments to the Electronics. Also, it is recommended that the sample run be a minimum of 10 seconds long. This will allow a reasonable amount of material to be run through the CentriFeeder™ Meter ensuring an accurate adjustment to the Calibration. The procedure is explained as follows:

- Step 1:** Make sure that the TOP.RUN page is accessed to begin the procedure. Press the Reset Button on the Lower Left to reset your count to zero before running product through the meter.
- Step 2:** Run product through the meter for a designated period of time, collecting the material in some manner after it has passed through the meter.

Step 3: After product has stopped flowing through the meter, go to the SET.FIELD page located under the SET option on the MAIN MENU. **HINT: Press the MENU softkey, then press SET, and finally, FIELD DATA.**



- Step 4:** Click on the “ENTER RUN” Button and you should see the GREEN value (CF Meter) change from “0.000” to a number signifying the weight that the electronics calculates passed through the meter.
- Step 5:** Weigh the collected material on a static scale and record the weight in the YELLOW block (Actual) next to the value automatically entered in STEP 4. Press the YELLOW box to bring up a numeric keypad. After entering the value, press the NEXT RUN Button to prepare for the next run. It is important that the container holding the material not be included in the weight. The only weight that is important is the material that actually went through the meter.
- Step 6:** Return to the TOP.RUN page and press the RED RESET Button on the bottom left.
- Step 7:** Repeat Steps 2-6 four more times to complete the 5 Field Data runs.
- Step 8:** Once all five runs are completed click on the RUN Number next to each set of data in order to select each data RUN. When selected the circles next to the numbers will become green as seen in the picture above.

- Step 9:** Now return to the TOP.SET page by clicking on the TO SET shortcut key in the top right corner. Now press the FIELD CALd Button.
- Step 10:** You should now be on the SET.CALd page. The newly calculated Dynamic Calibration can be seen on the left side of the page, while the current Dynamic calibration can be seen on the right side of the screen. If you would like to change your current settings with the settings that you calculated please move on to Step 11. If you would like to keep your current settings, please press the CANCEL Button.

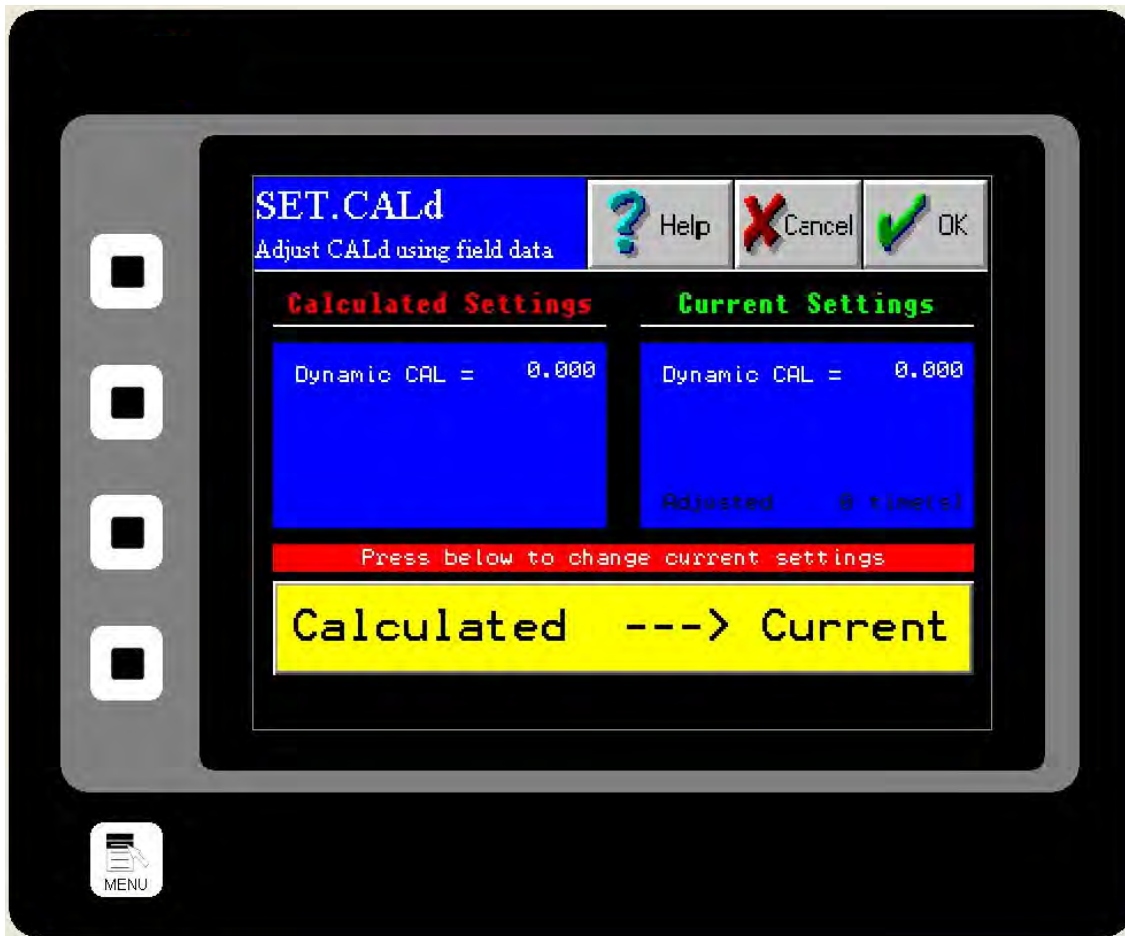

- Step 11:** To accept the new Dynamic Calibration press the YELLOW CACULATED to CURRENT Button and press the OK Button. A pop up screen will appear, asking if you are sure you would like to accept this value. Press YES.

Setting the Valve's Upper and Lower Limits - CentriFeeder with ICV only

The valve's upper limits (Maximum Auto Out) and its lower limits (Virtual Flow Stop) can be set from the Advanced Setting Menu.

Virtual Flow Stop

Virtual Flow Stop™ is a function of the CentriFeeder™ that allows you to manipulate the position of the blade of the Integrated Control Valve so that flow can be stopped without closing the Integrated Control Valve completely, thus, not damaging product and minimizing damage to the leading edge of the valve and the Tangential Back Plate as well.

Maximum Auto Out

Maximum Auto Out is a function of the CentriFeeder™ that allows you to set the upper limits of the valve ensuring the meter's accuracy by preventing a volumetric flow rate that exceeds the meter's capacity. In certain applications product may flow over the sides of the pan if the flow rate is too high. Maximum Auto Out may also be used as an alarm indication to warn that the upstream product flow may be constrained. Please note that setting the Maximum Auto Out on the ADV.PID2.LIMIT page will only provide an alarm that the signal has passed the Maximum Auto Out threshold. To actually limit the upper threshold of the valve, you must turn on the limiting function located at the ADV.CTRL.ICV.LIMITS page.

Setting the Virtual Flow Stop

To set the Virtual Flow Stop™ press the ADV Button from the TOP (Main Menu) page. Press the Control Modifications Button and from the ADV Menu and press the Slide Gate Valve Limits Button. Now press the Set VFS Button and you should be on the ADV.PID2.LIMITS page as shown to the right.

Press on the Virtual Flow Stop Button to open a numeric keypad and enter the percentage value you wish to set for your Virtual Flow Stop™. The Virtual Flow Stop™ is typically set by increasing the Manual Valve until flow just begins to trickle from the valve and then, set the Virtual Flow Stop™ to 2/3 of that value. This value is, of course, dependant on the particle size and characteristics of your product.

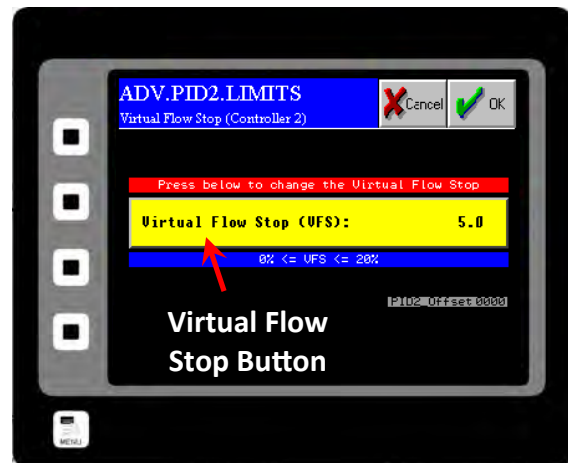

Please note that it is very important that the valve not stick or “crunch” upon closure. If this happens, increase the Virtual Flow Stop value to 85% of the “flow just starts value”. It is normal for the valve to “trickle” for a short period after a stop command as it established the Virtual Flow Stop condition.

Setting the Maximum Auto Out

For an upper limit alarm, you can set the Maximum Auto Out. To do so, press the ADV Button from the TOP (Main Menu) page. Press the Control Modifications Button and from the ADV.CONTROL Menu press the Maximum Auto Out Button. You should now be on the ADV.PID2.LIMITS page as shown to the right.

Press on the Maximum Auto Out Button to open a numeric keypad and enter the percentage value you wish to set for your Maximum Auto Out. The Maximum Auto Out should be between 50% and 100% of full scale.

PLEASE NOTE THAT THIS WILL ONLY SET THE ALARM FOR MAXIMUM AUTO OUT BUT WILL NOT ACTUALLY LIMIT THE UPPER CAPACITY OF THE CENTRIFEEDER™.

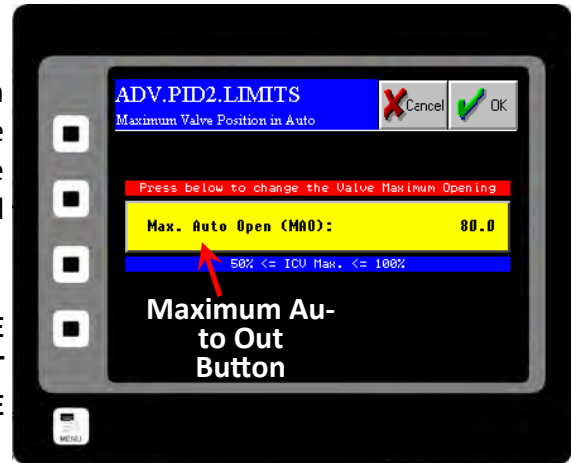

In order to limit the upper range of the CentriFeeder™, you must enable it. To do so, you must press the ADV Button from the TOP (Main Menu) page. Next, press the Control Modifications Button from the ADV Menu and then, press the Slide Gate Valve Limits Button. Next, press the Set Point 2 Enable Limit Button and you will be on the ADV.SP2.LIMIT page as seen to the right. Press ENABLE in order to enable the upper limit of the CentriFeeder™ (Maximum Auto Out) in order to actually limit the opening of the valve.

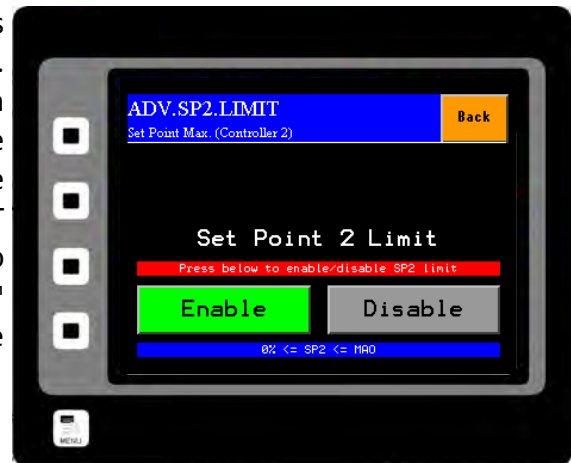

Setting the Auto Delay

Typically, the Integrated Control Valve, while in Automatic Mode, will take several seconds to “tune” in order to reach your set throughput value upon startup. In order to avoid a large overshoot the optimal method for startup is to either start in Manual Mode and enter a remembered Manual Out value, gathered through prior runs and then switch to Automatic Mode once the tuning has occurred for several seconds, or to set the Auto Delay which accomplishes this automatically. Auto Delay is a method of preventing control overshoot. In order to set Auto Delay, a delay time and a Manual Value or position for the valve to start in (equivalent to Manual Mode), must be calculated. The value is calculated using two known set points consisting of a known valve opening and a corresponding percentage of full scale. An example would be: (30% valve opening corresponding to an output of 26% of fullscale).

Setting the Auto Delay

From the TOP page (Main Menu) press the ADV Button and then press the Control Modifications Button. Now press the Auto Delay Button, revealing the screen above. Selecting the Auto Delay Time will enable the Auto Output to be held constant for the indicated time period (you can select from 1/4s, 1/2s, 3/4s, 1s, 2s, 3s, 4s, or you can turn Auto Delay off). The Auto Delay indicator can be seen by looking at the Run page (pressing the Run Button from the TOP page). Red indicates that the Auto Delay is enabled and active, and gray indicates that it is not currently active. To learn more about the Run page, please see the HMI Screen Guide section of this manual.

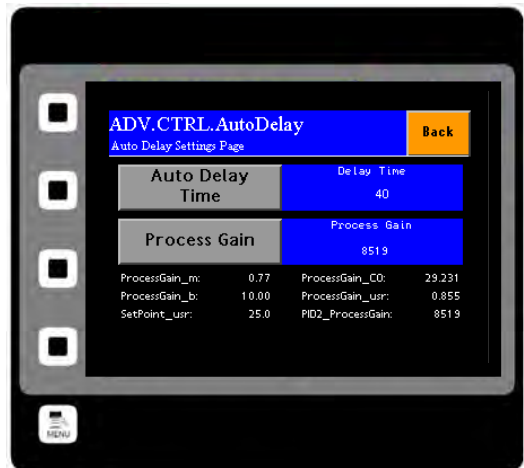

Process Gain

To calculate a Process Gain value, ensure you are in Auto Mode. Click on the Process Gain Button and you will see the ADV.CTRL.Pg page (right) where you can enter the two points mentioned above. Please note that the Y1 and Y2 values are percentages of Control Out (found on main run screen) that are achieved at the corresponding set points X1 and X2. Once entered, the Process Gain is calculated automatically.

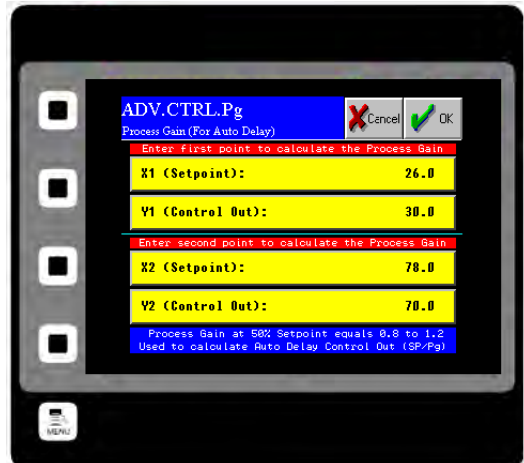

Note: In cases where the set point has been changed or if the feeder is run with no product and the valve opens to 100% open, upon restart, the new valve position will be calculated as mentioned above. Otherwise, the Auto Delay will retain the last known good valve position.

Stroking the Valve - CentriFeeder with ICV only

Stroking the Integrated Control Valve is a way of setting the position sensor output to correspond to the actual stroke or range of travel of the valve's blade. Stroking the valve may be required if the electronics package is replaced or the HMI is reprogrammed, however, new installations will typically include a properly stroked valve that will not need to be adjusted.

Please note that the operating stroke of the valve is 3.5". Mechanical Stops are the actual, mechanical endpoints (fully open and fully closed) of the valve's stroke. In order to properly stroke the valve, the electronic endpoints should be moved from these actual stops to 1% under the defined closed position and to 4% over the defined open position. This will prevent damage to the valve.

To stroke the valve, you must access the Position Sensor page. To access this page press the ADV Button from the TOP (Main Menu) page. Then, press the PID #2 Tuning Button and finally, press the Position Sensor Button. You should now be on the ADV.PID2.SENSOR page seen below.

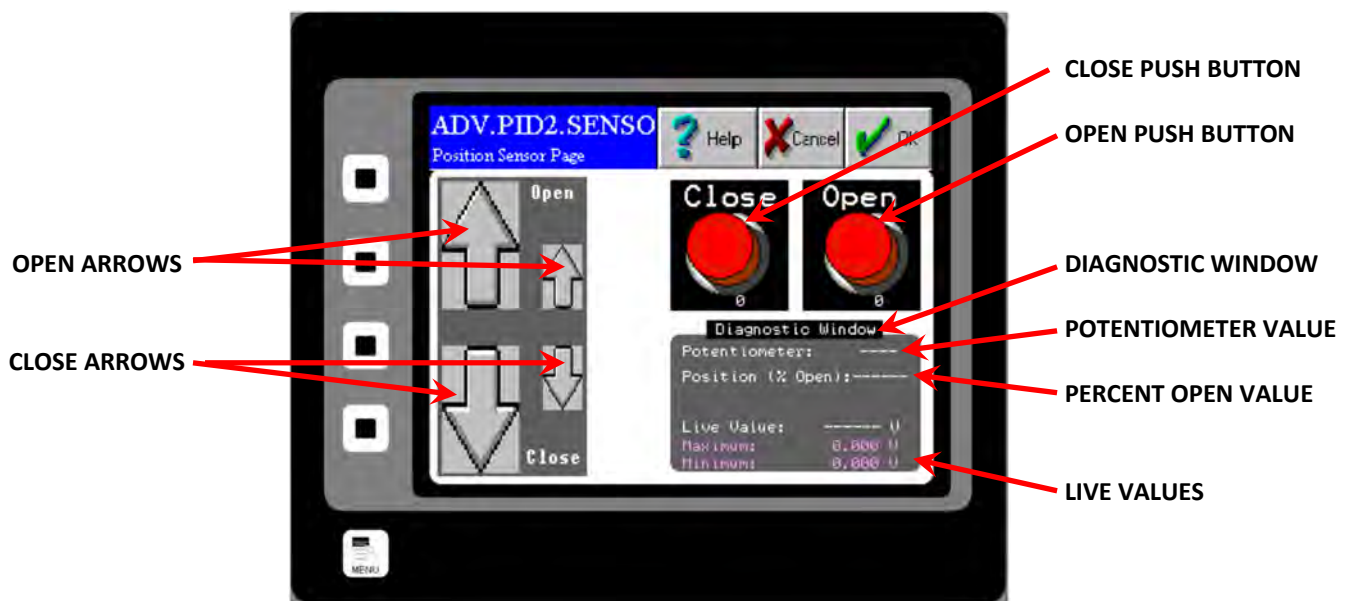

Step 1: Move the valve to the mechanical stops by depressing the Open or Close arrows. **DO NOT PRESS THE RED CLOSE or OPEN PUSH BUTTONS.** The large arrow produces a hard movement command and the small arrow produces a softer movement command. Use the small arrow for all movements towards the stops. Do not use the large arrow against the stops. It should only be used to bring the valve off the stops, if needed. The speed of travel is about the same for both arrows and takes less than a minute for a full stroke. The valve is at the end of its stroke when it quits moving as indicated in the Potentiometer value in the Diagnostic Window. Confirm the end of the stroke by moving off and then back on to the mechanical stop.



- Step 2:** Check your Percent Open values in the Diagnostic Window. The Percent Open values should read **+104% ($\pm 0.4\%$)** against the open stops and **-1% ($\pm 0.2\%$)** against the closed stops. The Maximum Live Value should be 2.0V, $\pm 0.25V$ the Minimum Live value should be 0.5V, $\pm 0.25 V$.
- Step 3:** If conditions described in Step 2 are met, then the valve is properly stroked and the valve position is correctly read into the system. If the conditions described are not met, continue to Step 4.
- Step 4:** Move the valve to the fully open position against the mechanical stops as described in Step 1 and press the Open Push Button. ***Please note that the Open Push Button and Open Arrows are not the same button!*** This will set the Percent Open Value to 100% in the Diagnostic Window.
- Step 5:** Close the valve to the fully closed position against the mechanical stops as described in Step 1 and press the Closed Push Button. ***Please note that the Closed Push Button and Closed Arrows are not the same button!*** You have now set your 0% and 100% values to the mechanical stops, so you must now set the Operating Stroke of the Valve.
- Step 6:** Since you are on the Closed mechanical stop, move the valve off the mechanical stop by 1%. You are now at the defined Closed Valve position. Again, press the Close Push Button. The Percent Open value should now be 0%. If you move the valve back to the mechanical closed stop, the value should read -1.0%.
- Step 7:** Now move the valve to the fully open position as described in Step 1. Ease it against the fully open mechanical stop The Percent Open value should be 100%. Back the valve off of the mechanical stop until the Percent Open value is 96%. You are now at the defined Full Open position. Press the Open Push Button. The Percent Open value should now be 100%. You may check by easing the valve back to the mechanical stop and confirm a reading of 104%. To verify that the stroking of the valve was successful, check your values against those specified in Step 2.

Helpful Hint:

If the valve becomes, inadvertently stuck against the mechanical stops, it can be freed by removing the access cover and with a large screwdriver, moving the large timing belt pulley in the direction required to free the valve. There is a direction arrow on the pulley indicating which direction causes the valve to open. If the valve is stuck in the open position, then the pulley should be turned in the closed direction. Do the opposite if stuck in the closed position. If you are unsure of the position, it may be determined by the Mechanical Position Indicator on the side of the valve.

PID Control Loop Tuning - CentriFeeder with ICV only

PID #1 and #2 control the ICV in what is termed a cascade control in which the control output of PID #1 becomes the set point of PID #2, which in turn, controls the valve. Set PID #1 according to the following table for Electronic Full Scale (eFS)= 100% Meter Volumetric Full Scale (vFS). Use the heaviest material to calculate the vFS.

TABLE 1
PID Values For ICV with 2.0 second maximum stroke
w/PID #2 $K_p=100$; $K_i=0$; and $K_d= 100$

	K_p	K_i	K_d
Conservative	0.031	0.125	0
Normal	0.062	0.187	0
Aggressive	0.062	0.250	0

If the vFS is other than 100%, then multiply the PID value by the ratio. For example, If vFS = 150% then multiply the respective PID values by 1.5. For Normal (default) setting, then:

$$K_p = 0.062 \times 1.5 = 0.093$$

$$K_i = 0.187 \times 1.5 = 0.28$$

$$K_d = 0$$

Setting the PID 1

From the TOP.MENU page, press the "ADV Advanced Control" button which will open the "TOP.ADV Advanced Control Page". Press the "PID #1 Tuning" button which will open the "ADV.PID" PID #1 Control Page. Press the "Kp", "Ki", or "Kd" buttons to enter the values above.

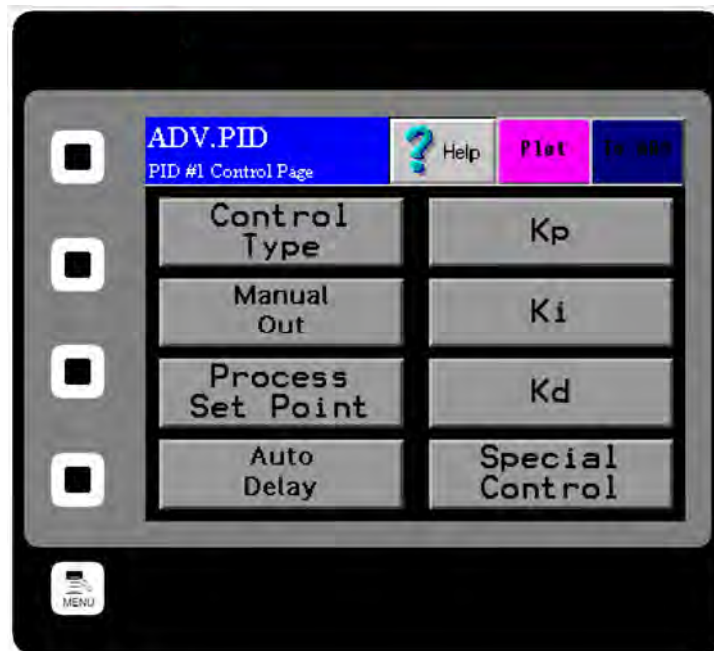



Running the CentriFeeder with ICV

Assuming that the meter has been properly installed and calibrated, your CentriFeeder™ can be run in one of two modes which can be quickly and easily switched between even while your process is running. These two modes are Manual and Automatic. These modes can be accessed from the main run display shown below. This display is accessed by pressing the Run Button from the TOP (Main Menu) page.

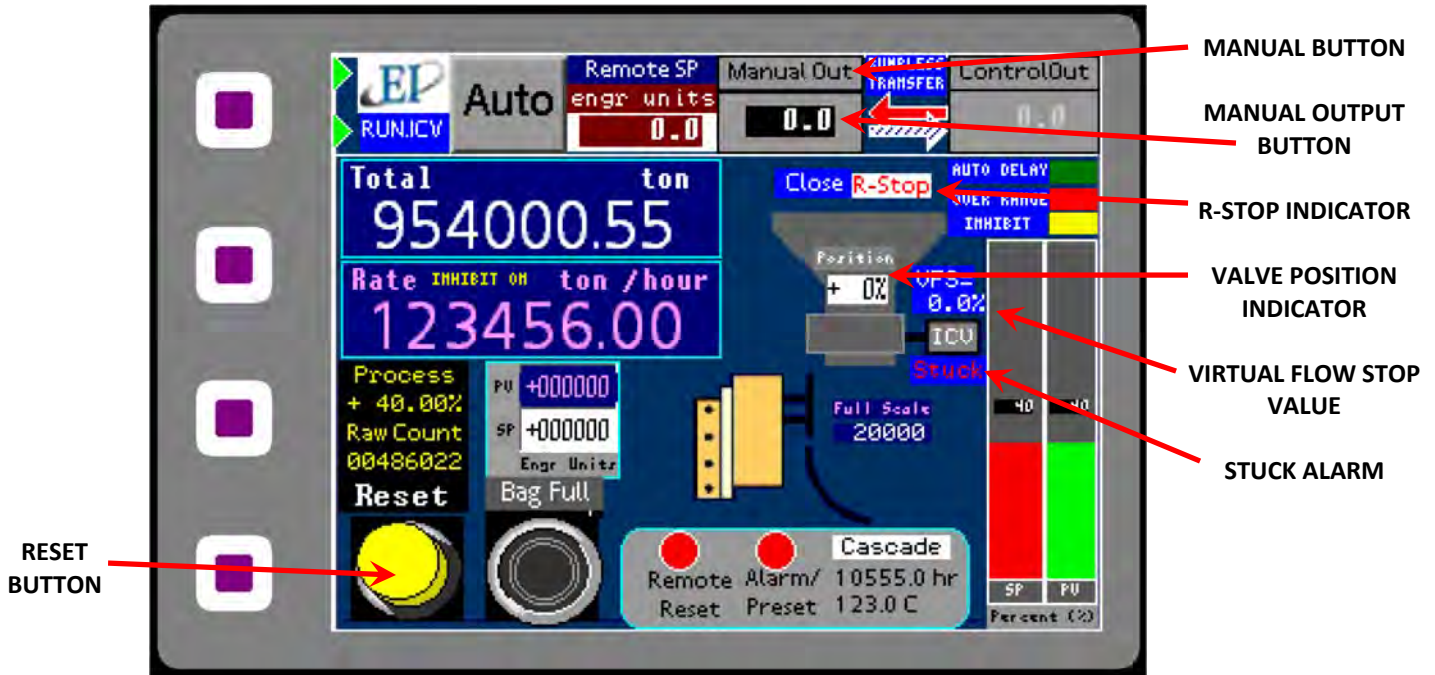

MANUAL

Entering Manual Mode

Manual Mode allows you to manually input the desired location of the valve by entering a value for the Manual Output. This allows more control of the flow, however, please note that starting and stopping the flow are manually controlled as well. To enter Manual Mode, simply press the Manual Out Button at any time, whether product is flowing through the CentriFeeder™ or not.

While in Manual Mode, you can manually enter values for the Manual Output of the CentriFeeder™. Your desired Manual Output, or the percentage that the valve is open, can be entered by double clicking on the Manual Out Button and entering your value in the pop up numeric keypad.



Starting Flow

Please Note: The ICV will not run if the R-Stop Indicator is visible on the screen. The valve will only operate if there is a closure between Customer Connections #18 and #19 and a jumper has been installed to serve this purpose. If this jumper has been removed, or the Remote Stop is engaged, the R-Stop Indicator will be visible onscreen.

If the Run/Stop Button is Red, then the valve is currently closed and product is not flowing through the CentriFeeder™. Press the Run/Stop Button so that it turns Green in order to open the valve to the desired position (as indicated by the entered Manual Out value). Once a value has been entered and the Run/Stop Button is Green, the valve will open and the actual position of the valve will be indicated by the Valve Position Indicator.

Please note that the valve will most likely have the ability to open to a point which will exceed the flow indicated by your Electronic Full Scale. The CentriFeeder™ will not be damaged, but you will experience an excessive amount of flow through the meter. Incremental changes in the valve's position are recommended if a large flow value is not desired. However, opening the valve to 100% can be useful to clear the valve of residual product when the feed hopper is empty in order to prepare for a product change.

Stopping Flow

To stop flow while it is running, (the Run/Stop Button is Green) press the Run/Stop Button. The Button should now be Red. Pressing this button will cause the valve to close to the Virtual Flow Stop value indicated above the Integrated Control Valve actuator icon.

If the valve does not close to within +1% of the target value in about 15 seconds, the Anti-Binding Function will activate, and try to close the ICV to within +1% of the closed target value. If it is not able to reach target in 3 minutes, a "Stuck" alarm will be activated. On closing, this is usually due to product bridging between the valve and Tangential Liner, and will usually open when asked. For more information, refer to the Anti-Binding Section of this manual.

AUTOMATIC

Automatic Mode is a mode that enables the valve's position, or output, to be changed automatically based on a desired process Set Point. The valve will automatically adjust until the Set Point is reached or maintained.

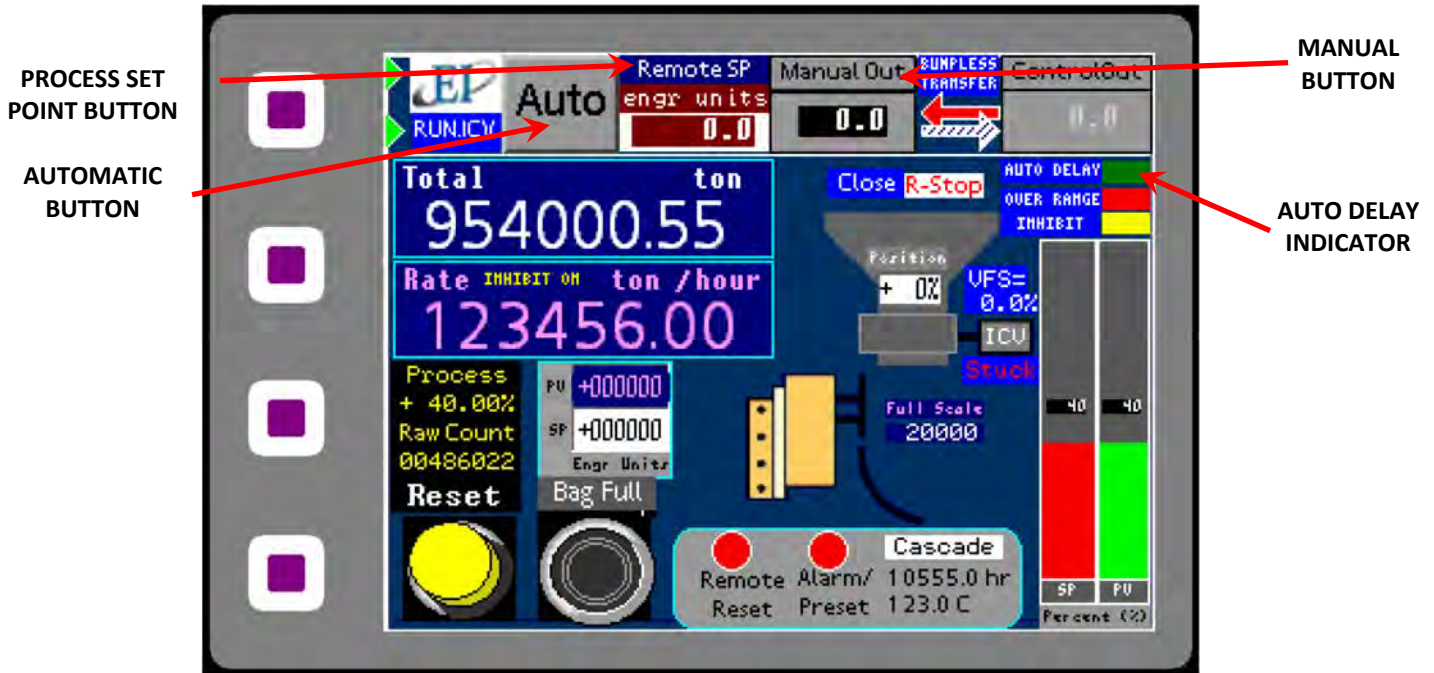

Entering Automatic Mode

You can access Automatic Mode from the Run page (pressing Run from the TOP page - Main Menu) by pressing the Automatic Button. You should now be in Automatic Mode. If you have not run the CentriFeeder™ before, then simply press the Run/Stop Button and when it has turned to green, the Integrated Control Valve will open.

If product has been run through the CentriFeeder™ before, then the stored Auto Delay value should be indicated in the Control Out Display. Pressing the Run/Stop Button will signal to the Integrated Control Valve to access the previously saved Auto Output value and will run in Manual Mode for the allotted time indicated in your Auto Delay Settings. After the Auto Delay set time has expired, the system will switch to Automatic Mode and you should see the Manual Button change from green to gray and the Automatic Button change from gray to green indicating that it has changed modes.

Changing the Set Point Value

The Process Set Point is similar to the Manual Output value for Manual Mode, however rather than indicating a percent open value for the valve itself, the Process Set Point indicates a percentage of your Electronic Full Scale value. This value can be changed by pressing on the Process Set Point Button and entering your value in the pop up numeric keypad.



CHANGING BETWEEN MODES

Auto to Manual

You can change from Automatic Mode to Manual Mode even while in process, by pressing the Manual Button. The Manual Button should now be green, indicating that Manual Mode is activated. The last Auto Output value will be transferred to the Manual Out Display, and the system will run at the new Manual Out value. Changing the Process Value will require changing the Man Out value via the keypad pop-up. Please note that while in Manual Mode, the Process Value will no longer be under automatic control.

Manual to Auto

You can change from Manual Mode to Automatic Mode even while in process, by pressing the Automatic Button. The Automatic Button should now be green, indicating that Auto Mode is activated. Changing to Automatic Mode will cause the Manual Output value to be transferred to the Auto Output value. Because you are in Automatic Mode, the Auto Output value will change, if necessary, to make the Process Value equal to the Set Point value. As long as there is not a significant change in the process, you should be able to change from Automatic Mode to Manual Mode and back again without a significant process change, at least for a short while.

ANTI-BINDING FUNCTION

If the Integrated Control Valve becomes stuck, it will put itself into “maximum impulse” and will attempt to free itself 5 times after which it will go into rest mode for a duration of 10 minutes. While in rest mode, the valve will move, however the power to the valve is reduced in order to prevent it from overheating. A “Stuck” warning will also appear on the main run page beneath the Valve Actuator Icon. In addition, a “Stuck” bit will be set in the assigned Modbus register for remote access.

Filling Mode using an Auxiliary Feeder

Filling Mode

Filling mode allows you to control the filling of any bag, box, bulk bag or other container. The filling mode works by allowing you to enter a target weight. Once a target weight has been selected, the electronics also needs to determine when to automatically shut off the feed device feeding the CentriFlow Meter in order to reach this target weight. If the feed device was signaled exactly when the target value was reached, the measured value would overshoot by a certain amount due to a variety of factors including the time that it takes the feed device to receive the signal and shut off, as well as the

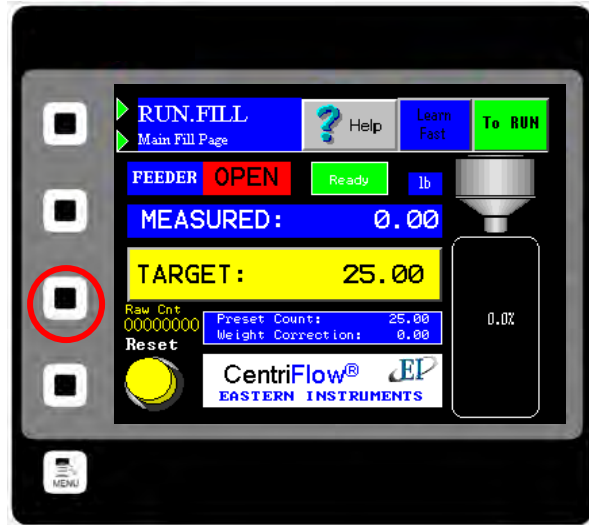

physical location of the feeder in respect to the meter. Once the feeder has been signaled to shut off, a certain amount of product will have already passed through the feed device but would not have been weighed or counted by the flow meter yet. The total value of this weight overshoot is called the Weight Correction. By determining the Weight Correction value as well as the target value, a precise shut off time for precise and accurate filling can be determined.

Accessing Filling Mode

To access Filling Mode, the first step is to access the filling screen or RUN.FILL page seen to the right. From the Main Menu press the PRF Button and then, press the Custom Page Select Button. Pressing the Primary Page or Secondary Page will cycle between various optional pages. Once the screen to the right is seen, press the OK Button in the top right hand corner. Selecting the RUN.FILL page as the Primary Page will allow you to see this page when on the Main RUN screen. If this page is selected as the Secondary Page, then it can be accessed by pressing the bottom soft key (circled) when on the Main Menu.

Setting Up the Filling Mode

To set up the Filling Mode you must enter/determine values for both the Target Weight as well as the Weight Correction value. To do so, you must access the Filling Setup page. This is found by pressing the ADV Button from the Main Menu and pressing the Filling Button.

You should now see the ADV.FILL page (right). Press the ENABLE Button in order to toggle the Fill Mode on and off. Press the CALCULATE TARGET Button in order to enter your filling parameters.

***Please note that filling using an Auxiliary Feeder only utilizes the Manual Target Weight Correction method. The Auto Target is a predictive method of determining the Weight Correction that is only used in conjunction with the CentriFeeder with ICV.**

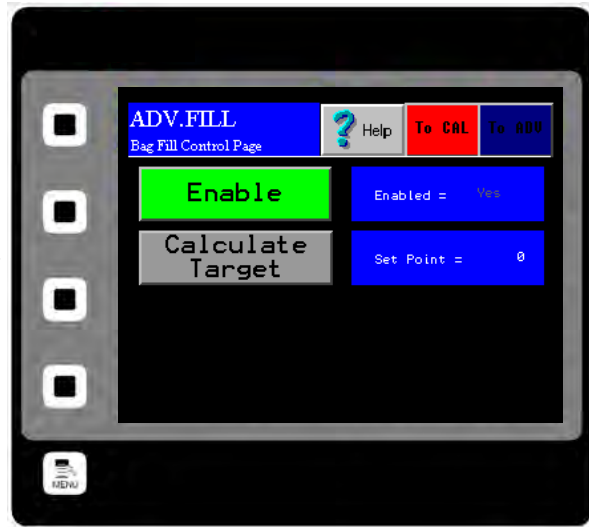

Bag Fill Target

Press the Manual Target Button. You should now see the ADV.FILL.MAN screen (right). Enter your target fill weight under Bag Fill Target by clicking on the 0.00 area. A numeric keypad will pop up where you can enter your weight.

Weight Correction

There are several ways to determine your Weight Correction. You can enter the weight correction if you already know the value (from previous runs), you can determine the value by completing a single run and entering the overshoot (weight over the Bag Fill Target), or you can run several runs in Learn Mode (explained in the Screen Guide).

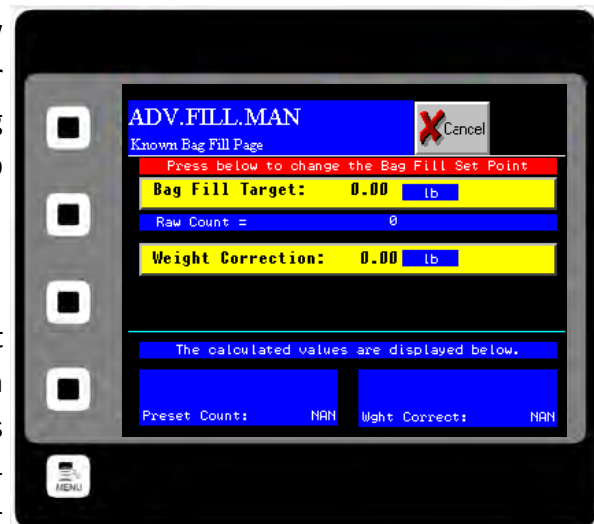

The preferred method would be to leave your Weight Correction at 0.00 lb and return to the filling screen or RUN.FILL page. Now run a single run and see once the feeder device has been shut off, how much overshoot has occurred. Please ensure that your Learn Mode is turned off. The overshoot that you see can be entered as the Weight Correction. Enter this value in the Weight Correction field, just as you entered the Bag Fill Target. Example: *If you have a Bag Fill Target of 25 lb and your first run is 26.5 lb, then the Weight Correction in this case would be 1.5 lb. Using this value as a starting point, refine the Weight Correction value by turning your Learn Mode to slow and complete several more runs until the Measured Target and the Bag Fill Target are within acceptable tolerances. Learn Mode should be left on slow.*

Setting the Alarm - Rate

To successfully utilize the alarm function of your Digital Electronics Package, please make sure that the alarm relay is wired according to the diagram in the Wiring Customer Connections-Alarm Outputs section of this manual. The relay can be used to trigger alarms which warn the operator that a batch is complete or that the rate has exceeded a set speed. The outputs are programmable to be assigned for rate or count. Below is a step by step procedure for setting a High Alarm for a Rate of 20 ton/hr.

Step 1: From the TOP.I/O page press the ALARM Button. Details of this page can be found in the HMI Screen Guide in this manual.

Step 2: You will now be on the I/O.ALARM page. Details of this page can be found in the HMI Screen Guide in this manual.

Step 3: Press the TYPE Button. Select 'Rate' from the pop up menu. Check the Blue display box to the right of the TYPE Button to make sure that "Rate" is displayed.

Step 4: You have chosen to set the alarm based on Rate. Now you must select a target value that will trigger the alarm. Select a Target Value by first pressing the TARGET Button.

Step 5: You should now be on the I/O.ALARM.SP page. Press the RATE TARGET Button. Details of this page can be found in the HMI Screen Guide in this manual.



Step 6: You should now see the I/O.RATE.SP page. The Rate Target Button is highlighted in Yellow. You can change the Rate Target by pressing the current Rate Target value twice. The first press will outline the value in black, as shown. The second press will bring up a numeric keypad and the Target Rate can be changed. The maximum value that can be used is Full Scale, which is displayed in a dark Blue highlight.



Step 7: Now return to the I/O.ALARM page. Make sure that the blue display box to the right of the LOGIC Button says Positive. If it does not, press the LOGIC Button until it does. Details on the LOGIC Button can be found in the HMI Screen Guide for the I/O ALARM PAGE.

Step 8: Return to the I/O.ALARM page once more. To turn the alarm on, press the ENABLE Button until "YES" is displayed in the blue display box to the right of the ENABLE Button.

Setting the Alarm - Totalization

To successfully utilize the alarm function of your Digital Electronics Package, please make sure that the alarm relay is wired according to the diagram in the Wiring Customer Connections-Alarm Outputs section in Chapter 1 of this manual. The relay can be used to trigger alarms which will either hold for a period of time after a set Total has been reached, or will latch indefinitely until the Total is reset. Below is a step by step procedure for setting a Totalization Alarm.

Step 1: From the TOP.I/O page press the ALARM Button. Details of this page can be found in the HMI Screen Guide in this manual.

Step 2: You will now be on the I/O.ALARM page. Details of this page can be found in the HMI Screen Guide in this manual.

Step 3: Press the TYPE Button. Select 'WEIGHT' from the pop up menu. Check the Blue display box to the right of the TYPE Button to make sure that "Weight" is displayed.

Step 4: You have chosen to set the alarm based on Weight, or Totalization. Now you must select a target value that will trigger the alarm. Select a Target Value by first pressing the TARGET Button.

Step 5: You should now be on the I/O.ALARM.SP page. Press the WEIGHT TARGET Button. Details of this page can be found in the HMI Screen Guide in this manual.



Step 6: You should now see the I/O.WEIGHT.SP page. The WEIGHT TARGET Button is highlighted in Yellow. You can change the Weight Target by pressing the current Weight Target value twice. The first press will outline the value in black, as shown. The second press will bring up a numeric keypad and the Target Weight can be changed. The acceptable range for a Weight Target is displayed at the bottom of the WEIGHT TARGET Button.



Step 7: Now return to the I/O.ALARM.SP page by pressing the OK Button in the upper right hand corner of the screen. You must now choose which type of Weight Output you would like to utilize. Press the WEIGHT OUTPUT Button for your options. You should now be on the I/O.WEIGHT.OUT page. More information on the two types of Weight Output, Pulse and Latch, can be found on the I/O.WEIGHT.OUT page in the Screen Guide section of the manual.

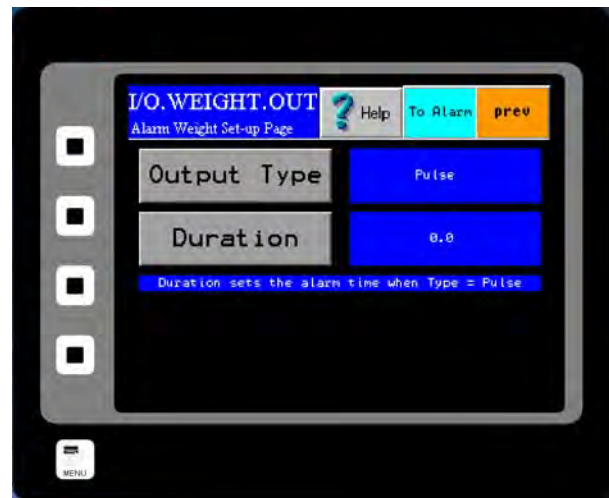

Step 8: If a Pulsed Weight Output is chosen, you should enter a duration for the Pulsed Alarm. This is accomplished by pressing the DURATION Button, double clicking on the old duration value and entering your new duration value via the numeric keypad as before and press the OK Button.

Step 9: Return to the I/O.ALARM page by pressing the TO ALARM Button on the upper right hand corner of the screen. You must now select your logic. Press the LOGIC Button and select your logic. Details on the LOGIC Button can be found in the HMI Screen Guide for the I/O ALARM PAGE.

Step 10: Return to the I/O.ALARM page once more. To turn the alarm on, press the ENABLE Button until "YES" is displayed in the blue display box to the right of the ENABLE Button.

Setup of Remote Reset Capability

What is Remote Reset?

Remote Reset allows you to remotely trigger a reset of the Totalization on your Digital Electronics. This feature is similar to pressing the RESET Button from the TOP.RUN page. The Remote Reset can be utilized by installing a remote push button on/off switch (customer supplied). To properly wire the push button on/off switch for Remote Reset Capabilities, please see the Wiring Customer Connections section of Chapter 1.

Enabling the Remote Reset Capability

Once the switch is wired properly, you must enable the Remote Reset. To enable the Remote Reset Capability, access the I/O Menu from the TOP.MENU page and click on the REMOTE RESET Button. You should now see the page shown to the right. To enable Remote Reset, simply press the ENABLE BUTTON. If enabled, the word "Yes" will be displayed to the right of the button.



The Type Button allows you to toggle between Remote Reset, Remote Zero or both simultaneously.

The logic of the Remote Reset Capability can also be manipulated. If the LOGIC Button is pressed, a dialog box will prompt you to chose from two options, "NC" or "NO". The options are described below.

- NC** - Normally Closed
- NO** - Normally Open

Using the Compact Flash

Using the Compact Flash Card

A 2 Gigabyte Compact Flash card is pre-installed inside the Digital Electronics Enclosure and is located inside the enclosure on the reverse side of the HMI touch screen. Run data is stored on the Flash Drive but only when the TOP.RUN page is currently displayed. The internal data logger operates using two separate processes. The first samples each data point at the rate specified by the factory (1/second), and places the logged data into a buffer within the RAM of the panel. The second process executes every minute, and writes the data from RAM to the Compact Flash card. Note that because data is not committed to the Compact Flash for a minute, this amount of log data may be lost when the terminal is powered-down. Further, if the terminal is powered-down while a write is in progress, the Compact Flash card may be corrupted. Data is being written to the Compact Flash card when the middle yellow LED light on the front of the HMI panel is flashing. Do not turn the power off or remove the Compact Flash while the yellow LED is blinking!

Removing the Flash Card

The process for removing the Compact Flash card is called Hot Swapping. Hot Swapping is not the preferred method of transferring data from the flash card to an external source due to the possibility of data files being corrupted if the Flash card is removed improperly. Please remember that the Compact Flash card cannot be removed while data is being written to the Flash card, or when the yellow LED is flashing.

To Hot Swap, go to the TOP.COM page by pressing the COM button from the main menu.

Next, press the Remove CF button and finally, press the SAFELY REMOVE COMPACT FLASH button. When the 'Safe' prompt is indicated, you may safely remove the Compact Flash card.

Open the Electronics Enclosure and remove the Flash card from the back of the HMI panel in the door of the Electronics Enclosure.



Save Settings

You can also save your settings and configurations to your Flash Card and restore them if your settings have been unintentionally changed. To save your HMI settings to a Flash Card (provided you have one installed), press the COM Button from the TOP Menu to enter the TOP.COM page (seen on right). Now, press the Save Settings Button. You will be prompted with "Do you want to save the HMI configuration to flash?" Press "Yes" to save the configuration settings.



Restore Settings

This allows you to restore the saved configuration settings in the event that your settings have been changed on the HMI. From the TOP.MENU page, press the COM Button to enter the TOP.COM page. Press the Restore Settings Button. Again, you will be prompted with "Do you want to load the HMI configuration from flash?" Press "Yes" to load the settings from the flash card. This procedure will fail if no flash card is present, or previous HMI settings have not been saved to the Flash Card currently installed in the HMI.

Please note that as data is saved on your Compact Flash Card and the Card reaches its data storage capacity, the HMI will begin overwriting the oldest data as the newest data is saved to the Compact Flash Card.

Remote Ethernet Access Capabilities

The preferred method for transferring data from the Compact Flash card is to link the Digital Electronics to a PC or Laptop using an Ethernet Cable. The main advantage of the remote viewing capability is that run histories can be viewed and saved from the Electronics itself to a hard drive or other desired external storage device.



Digital Electronics connected via Ethernet Cable to a Laptop
Note: Crossover cable may be required for communication directly between HMI and a computer

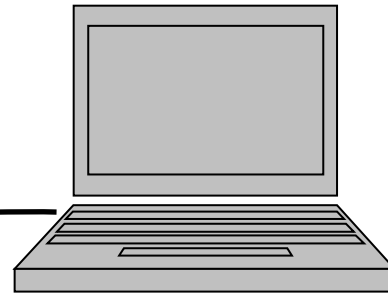

Establishing Communication

The IP address and Subnet Mask for the Digital Electronics has been factory set as:

IP Address: 192.168.2.90
Mask: 255.255.255.0

NOTE: IF YOUR CENTRIFEEDER™ WAS SUPPLIED AS PART OF A LARGER SYSTEM OR MULTIPLE UNIT SYSTEM, THE IP ADDRESS MAY BE DIFFERENT THAN SHOWN ABOVE.

In order to enable communication, the Local Area Connection Properties of the PC/Laptop must be set appropriately.

Please read the following if you are using Internet Explorer as your Internet Browser. Make sure that in your Advanced Internet Options Menu, under Tools, under the Phishing Filter option, that the "Automatic Website Checking" is off.

Once TCP/IP settings are complete and the Ethernet Cable linkage is made, your Internet Browser can be used to access the Digital Electronics by entering the IP address into the Address Bar. When entering the IP address please enter in the format illustrated below:

http://###.###.#.###

Entering the Digital Electronics IP Address will bring up a web page entitled “G3 Web Server”. This page will allow you access to three options, View Data, View Logs, and Remote View.



Remote View

Selecting the Remote View option will allow you to access the various pages of the HMI touch screen from a remote location. Upon clicking the Remote View link, a screen that looks identical to the HMI touch screen will appear in the Web Browser window. Clicking on the various options works similarly to using the touch screen on the Digital Electronics itself. In this way, all of the features of the HMI can be accessed and used remotely.

View Logs

Selecting the View Logs option allows access to the log files stored on the Compact Flash. Three files are created when the compact flash is formatted— MMDDYY.csv, UserSet.csv, and MTR.csv. They are all comma separated variable files. The MMDDYY file store the run data. One run data history file is created upon startup of the Digital Electronics and a new file is subsequently created every 24 hour period. The names of the files themselves indicate the date upon which the file was created and the data therein was collected. The UserSet file records a history of changes to the meter calibration. The MTR file records the site calibration data. MTR is an abbreviation for Material Test Report.

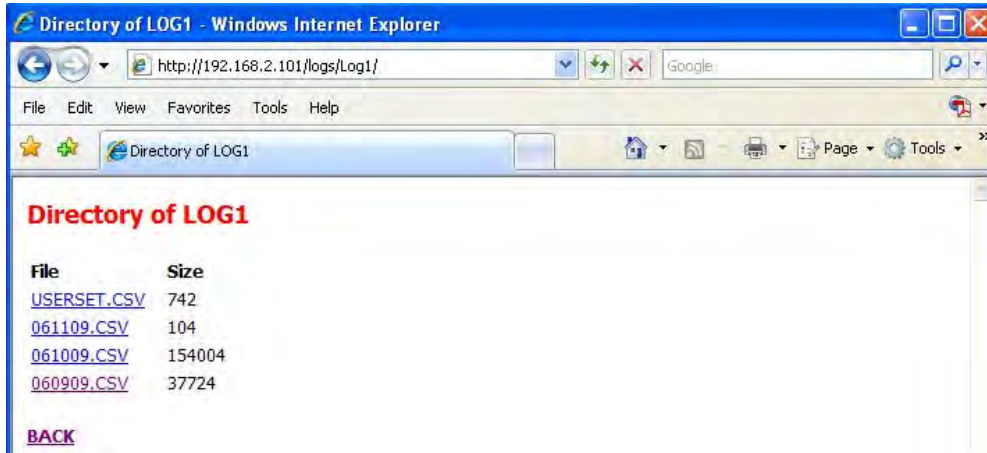

Clicking on any of the file names will open up the data file. These files are CSV files and typically open into an Excel spreadsheet. Once open, the spreadsheet can be saved to another location such as a hard drive. A typical entry would look like the file below.

TIME (HR:MIN:SEC)	RAW (Count)	ENGR (Count)	Volts (%)	PV (%)	RATE (Mass/Time)	ALARM (Over)
14:55:30	50	0.27778	18.18	1817	1817	0
14:55:31	183	1.0167	27.46	2745	2745	0
14:55:32	318	1.7667	23.9	2390	2390	0
14:55:33	435	2.4167	25.52	2551	2551	0
14:55:34	560	3.1111	25.13	2512	2512	0
14:55:35	673	3.7389	24.97	2497	2497	0
14:55:36	823	4.5722	25.49	2548	2548	0
14:55:37	935	5.1944	24.98	2497	2497	0
14:55:38	1061	5.8944	25.13	2513	2513	0
14:55:39	1199	6.6611	25.41	2540	2540	0

The TIME column indicates the specific time, using a 24 hr clock, the count data was taken. The second column indicates the RAW COUNT, while the third column is the ENGINEERING COUNT. The RAW COUNT divided by the C/W RATIO equals the ENGINEERING COUNT. The next two columns are both measurements of the full scale, but shown in different units. The unit (% Volts) is used in the Static Calibration procedure. The units (% PV) or Process Variable, is the calibrated full scale measurement. The two units, (% Volts) and (% PV) are mathematically related by the CALd multiplier. The RATE column indicates the flow rate in the mass and time units chosen. The final column, ALARM, indicates whether or not the alarm has been triggered. (Note: The (% PV) column is recorded as an integer with an implied decimal point. Divide the (% PV) column by 100 in order to get the correct real number.)



The User Settings Log indicates each time that the user settings have been changed and what the new settings are. A typical Userset page can be seen below.

DATE	TIME	EVENT	ZERO	CALs	CALd	RANGE	INHIBIT	FILTER	CWratio	Full Scale
6/2/2009	14:47:54	Power On	7FEF	10D0	2710	4	2	14	180	10000
6/2/2009	14:49:08	zero	7FDC	10D0	2710	4	2	14	180	10000
6/2/2009	14:49:30	CALs	7FDC	10F2	2710	4	2	14	180	10000
6/2/2009	14:55:11	Power On	7FDC	10F2	2710	4	2	14	180	10000

The MTR Setup Sheet allows data to be loaded to it and to calculate the Standard Deviation and the Percent Error of the Electronics' readings. This file stores site calibration data to the compact flash from the SET.SAVE page. A standard MTR Setup Sheet can be seen below.

MM-DD-YY:	5/21/2009	TIME:	15:11:47		
Material:	rice shortcb				
Technician:	sjt				
Location:	wh				
Type:	Type I	Reverse			
Model:	CFM-12				
Feed:	Belt				
Full Scale:	1000				
Zero:	7F5C				
CALs:	0C5D				
CALd:	3198				
RUN	ACTIVE	METER WEIGHT	ACTUAL WEIGHT	ACTUAL/METER	%ERROR
1	1	30.267	30.46	1.0064	-0.63
2	1	30.567	30.72	1.005	-0.5
3	1	26.433	26.56	1.0048	-0.48
4	1	30.567	30.72	1.005	-0.5
5	1	28.233	28.42	1.0066	-0.66
			Average:	1.0056	
			STD:	0.0009	
			%STD:	0.0857	

View Data

This option is not used.

Changing the Ethernet/IP Address (Optional)

If you have purchased the Ethernet/IP Option read on for the procedure to set up your IP Address to communicate with your existing PLC. The Ethernet/IP option allows you to output both the flow rate and the totalization signals via an Ethernet connection, directly to your PLC. The main tasks involved to successfully enable this option are to physically connect your HMI to your PLC, to assign an appropriate IP Address to your HMI and then, to instruct your PLC to accept the signal through your Ethernet connection.

Step 1: Install your Ethernet Cable into the RJ45 connection (Ethernet NIC) on the back of your HMI. To access the back of your HMI, simply open the door of your Digital Electronics Unit. The HMI is attached to the door itself. Please see the drawing (Below) for the location of the RJ45 Connection.

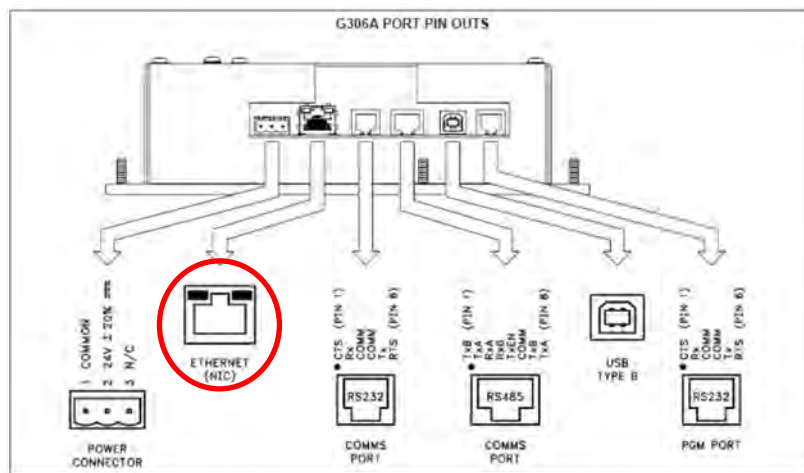

Step 2: You must first Manually Configure the IP Address for your Digital Electronics. In order to accomplish this, you must first access the COM.IP page by pressing the COM Button on your TOP Menu and then, pressing the IP CONFIG Button. You should now see this screen (right).

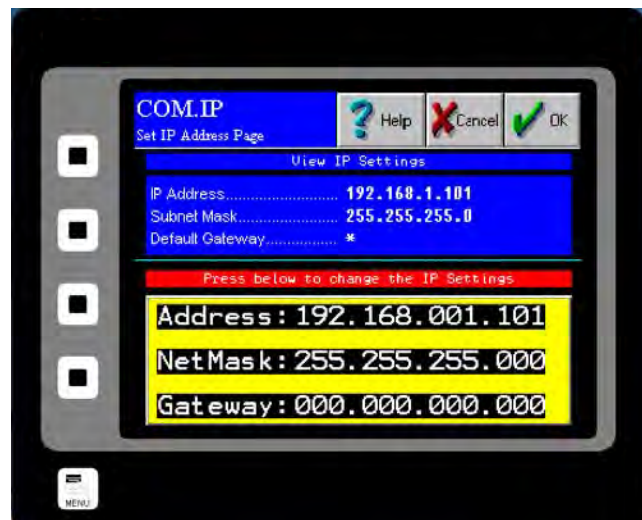



Step 3: Enter the IP Address for your HMI by double clicking on the Address section. To switch between numbers and letters, press the SYMBOL Button that is located next to the IP Address display.

*Please note that pressing the PREVIOUS and NEXT Arrow Keys will scroll between your Address, NetMask and Gateway Fields until you have begun entering your IP Address numerically. At that time, the PREVIOUS and NEXT Arrows will move the cursor back and forth to edit your IP Address.

Step 4: After entering the IP Address for your HMI, press the ENTER key and then, press the OK Button located in the Upper Right hand corner. A pop up will prompt you to save the IP Address changes to your Flash. Pressing the YES Button will refresh the HMI and will implement the changes made.

Step 5: You have now configured your HMI to communicate with your PLC and must ensure that your PLC will receive the output from your HMI. The following section offers a specific example of PLC configuration using a ControlLogix PLC.

Example of Establishing Communication To PLC: ControlLogix Unit

Set Comm Format to "Data-Real"

Input Assembly Instance must be set to 2.
Input Size must be set to 10.

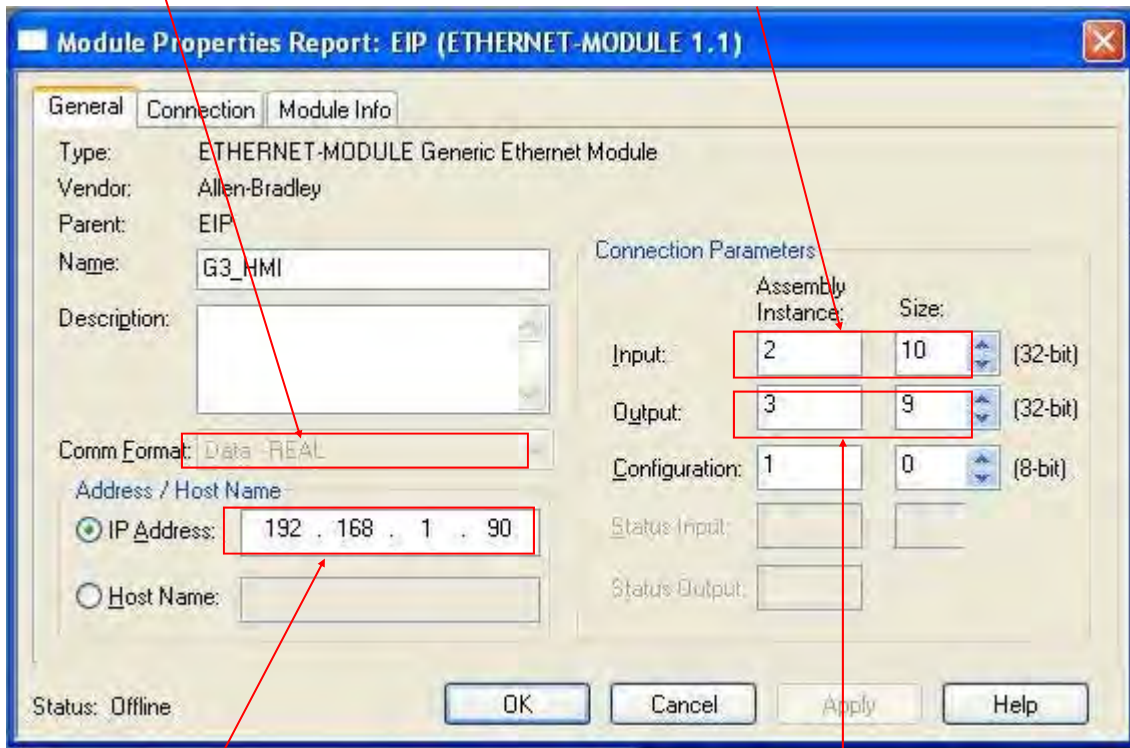

The IP Address is the address of the HMI.
This must be the same as the address set in the HMI.

Output Assembly Instance must be set to 3.
Output Size must be set to 7.

The diagram above is a screen capture from RSLogix 5000 software. See Red Lion Technical Note TNO17 for a description of the ControlLogix configuration steps. Note that the Module Properties as shown above and on page 3 of the technical note differ. Please set the Comm Format to Data-Real, Input Size to 10, and Output Size to 9, as shown above.

Set the Comm Format, IP Address, and Connection Parameters as shown in the diagram. Configuration data is not supported by the HMI. However, enter 1 for the Configuration Assembly Instance and 0 for the Configuration Size.

For more detailed instructions, please see Technical Note TNO17 on our website.

Tag Mapping

Name	Unit	Value	Origin	Unit	Data Type	Description
+ G3_HMI:C		{...}	{...}		AB:ETHERNET_MODULE:C:0	
- G3_HMI:I		{...}	{...}		AB:ETHERNET_MODULE_REAL_40B...	
- G3_HMI:I.Data		{...}	{...}		Float REAL[10]	
G3_HMI:I.Data[0]		0.0		Float REAL	Rate	rate
G3_HMI:I.Data[1]		0.0		Float REAL	Totalization	total
G3_HMI:I.Data[2]		0.0		Float REAL	Zero Readback	0 readback
G3_HMI:I.Data[3]		0.0		Float REAL	Product	Product
G3_HMI:I.Data[4]		0.0		Float REAL	Remote Alarm	Alarm Target
G3_HMI:I.Data[5]		0.0		Float REAL	Current Temp.	Temp
G3_HMI:I.Data[6]		0.0		Float REAL	Valve Position	Valve Position
G3_HMI:I.Data[7]		0.0		Float REAL	Setpoint %	Setpoint%
G3_HMI:I.Data[8]		0.0		Float REAL	Setpoint ENG	Setpoint ENG
G3_HMI:I.Data[9]		0.0		Float REAL	Status	Status
+ Status		67		Decimal INT		
- G3_HMI:O		{...}	{...}		AB:ETHERNET_MODULE_REAL_36B...	
- G3_HMI:O.Data		{...}	{...}		Float REAL[9]	
G3_HMI:O.Data[0]		0.0		Float REAL	Remote Reset	Reset
G3_HMI:O.Data[1]		0.0		Float REAL	Remote Zero	0
G3_HMI:O.Data[2]		0.0		Float REAL	Remote mCal	Product Select
G3_HMI:O.Data[3]		0.0		Float REAL	Remote dCal	dCAL Select
G3_HMI:O.Data[4]		0.0		Float REAL	Remote Alarm	Alarm Target
G3_HMI:O.Data[5]		0.0		Float REAL	Start/Stop Valve	Start/Stop
G3_HMI:O.Data[6]		0.0		Float REAL	PID#1 Setpoint	PID#1 Setpoint
G3_HMI:O.Data[7]		0.0		Float REAL	Manual/Auto Select	Man/Auto
G3_HMI:O.Data[8]		0.0		Float REAL	Clean ICV	Clean ICV

Data Received by PLC from HMI (Optional)

There are 10 input tags, I.Data[0] - I.Data[9]. As shown in the diagram above, Rate is mapped to I.Data[0], Total is mapped to I.Data[1], Zero Readback is mapped to I.Data[2], Product is mapped to I.Data[3], Remote Alarm is mapped to I.Data[4], the meter's current temperature is mapped to I.Data[5], the Integrated Control Valve's Position in Percent is mapped to I.Data[6], the Set Point for the read back register (in Percent) is mapped to I.Data[7], the Set Point for the read back register for Set Point (In Engineering Units) is mapped to I.Data[8] and the Status (i.e. PLC enable, Manual/Auto Mode, Start/Stop, Percent/Engineering Units, Valve Stuck) is mapped to I.Data[9].

Commands Transmitted by the PLC to HMI (Optional)

There are 9 output tags, O.Data[0] - O.Data[6]. As shown in the diagram above Remote Reset (Resets the total) is mapped to O.Data[0], Remote Zero (Resets the Zero) is mapped to O.Data [1], Remote Multiple Calibration is mapped to O.Data[2], Remote Dynamic Calibration is mapped to O.Data[3], Remote Alarm Target (lets you remotely set the alarm's target) is mapped to O.Data[4], Start/Stop, or process on/off is mapped to O.Data[5], Set Point is mapped to O.Data[6], Selection of Manual/Auto Mode is mapped to O.Data[7] and a clean ICV feature is mapped to O.Data[6]. Please note the units as expressed in "Status" bit I.Data [5].



CONTROLLER TAGS			
Data Sent to the PLC			
Address	Description	HMI Internal Tag	Comments
C02:00	Flow Rate	DS_rate (real)	Displayed on run page as "Rate"
C02:01	Totalization	counter_eng (real)	Displayed on run page as "Total"
C02:02	Remote Zero Readback	PLC_zero_rdbk (real)	1-norm; 2-abnorm; 3-prohib/not done; 4-prohib/abnorm; 5-prohib/PV > inhibit
C02:03	Remote mCAL Readback	PLC_MCAL_rdbk (real)	Readback for "Remote Product"
C02:04	Remote Alarm Target Readback	PLC_CompareTarget_rdbk (real)	Readback for "Remote Target"
C02:05	Current Temperature	PLC_temperature_read (real)	Temperature in °C
C02:06	Valve Position	PID2_position (real)	Displayed on run page as "ICV Pos"
C02:07	SP % Readback	PID_SetPoint_Value (real)	Displayed on run page as "Process SP"
C02:08	SP Eng Readback	PID_SetPoint_Engr (real)	Displayed on run page as "SP"
C02:09	BIT 0 Local/Remote Control	PB_PLC_enable (flag)	0=Local Control; 1=Remote Control
C02:09	BIT 1 Manual/Auto SP (PID#1)	PID_Type_Value (int)	0=Manual SP; 1=Auto SP
C02:09	BIT 4 Valve Open/Valve Closed	RB_DOUT1 (int)	0=Valve Closed/Off; 1=Valve Open/On
C02:09	BIT 6 %/ENG SP	PB_PLC_engr (flag)	0=%; 1=ENG
C02:09	BIT 7 Valve Free/Valve Stuck		0=Free; 1=Stuck
Data Received from the PLC			
Address	Description	HMI Internal Tag	Comments
C03:00	Remote Reset	A:PB_cntr_reset	Resets Totalization 0=normal; 1=reset
C03:01	Remote Zero	EIP_zero_PV (real)	Zeros the PV
C03:02	Remote mCAL	EIP_MCAL_sel (real)	Selects Product Preset (1-8)
C03:03	Remote dCAL	EIP_MCAL_remote (real)	Selects dCAL (4-10)
C03:04	Remote Alarm Target	EIP_CompareTarget (real)	Alarm Weight Target (0.01-999999.99)
C03:05	Start/Stop Valve	PLC_start (real)	Starts/Stops the process (edge triggered)
C03:06	PID#1 SP	PID_SetPoint_Value (real)	Remotely Sets SP (dependant on format)
C03:07	Manual/Auto Control		Switch Modes 0=Manual, 1=Auto
C03:08	Clean ICV		Switch from 0 to 1 in order to clean ICV

PLC Programming Note:

The valid values for Reset are 0 for normal operation and 1 in order to reset the total. Reset can be programmed for level or edge triggered from the HMI OPT.PLC page. The valid values for Remote Zero are 0 for none and 1 to perform the zero calibration.

The valid values for Remote Product (Multiple Calibration) are 1 thru 8 which select products 1 thru 8 respectively. 0 can also be utilized which will use the Remote d(cal) value.

Setup of Multiple Calibration Screens (Optional)

The Multiple Calibration Screens option allows you to run more than one product through your meter without having to recalibrate each time the product is switched. This option allows you to store up to 8 product calibrations at one time. To access the option once it has been purchased, press the MULTIPLE CAL Button from the TOP.OPT page, accessed by pressing the OPTIONS button from the TOP Menu. You will now be at the screen shown below.

From this screen, you are able to differentiate your different products by assigning them names and Dynamic Calibrations that are specific to each product. You can also choose the Calibration you will be using from this menu.



Please note that the first time the Multiple Calibration Option is selected, the screen to the right may be displayed unless the option was ordered prior to shipment in which case the option would be unlocked at the factory. If you have purchased the option, you will receive a 7-digit password. Enter the password when prompted to unlock the Multiple Calibration Option. If you have not purchased the option and would like to, or if you are having problems unlocking the option, please contact Eastern Instruments for assistance.



Step 1: The first step is to enter names and positions for each of your products. To do so, press the NAME Button. You should now see this screen (Right). Select the product you would like to name if none have been previously selected, select Product 1.



Selecting the product above will allow you to rename the selected product. Although this step is not necessary in order to continue it will help you differentiate your products and their calibration voltages in the future. Once a product is selected, you should see the screen (Right).

Step 2: You can now assign the product calibration a name. Often, the name of the product itself is used, but any name can be used. Double click the presently entered value for Name and you will be prompted to enter your product's name. When finished, press the ENTER Button and then, press the OK Button in the Upper Right hand corner. Press the TO MCAL Button to return to the Multiple Calibrations page.



Step 3: Now you should be able to enter your calibrations for each of the products that you have assigned with names. You should have been returned to the OPT.MCAL Menu. If not return there now and press the ASSIGN Button. You should now see this screen (Right).



Continued on next page

If you have named your products, then you should see them listed on this page. Select the product that you would like to assign a calibration voltage and press the corresponding button. You should now see this page (Right). Your Digital Electronics' current Dynamic Calibration value is displayed in the Current Cal(d) table on the left hand side of the page. If this is the correct dynamic calibration for your particular product, press the CURRENT/PRODUCT Button (Yellow) and then, press OK. Please note that if more than one product will have the same Dynamic Calibration, they must be entered one at a time from the previous page.



Step 4: If the current Dynamic Calibration is not correct for your particular product and you would like to change it, or none has been specified, you can either enter one manually or you can calculate another value by running a Site Calibration. To run a Site Calibration, please see the Site Calibration section of the Procedures section of this manual.

Step 5: To manually enter a Dynamic Calibration, return to the main TOP Menu and press the CAL Button and then, press the CALd Button. You should now see this screen (Right). Double click the current value for Dynamic Calibration and enter your new value. Press the ENTER Button when finished and then, press the OK Button in the Upper Right hand corner.

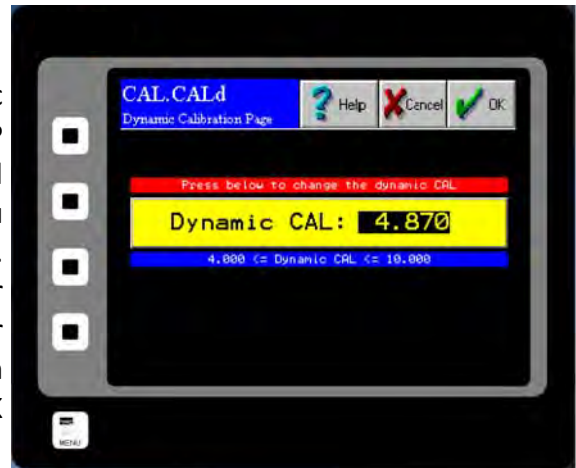

Step 6: Once the value is entered return to the OPT.MCAL.SAVE page as described above and save the new current Dynamic Calibration to the selected product. Repeat this process for all of your products, up to 8.

Step 7: To access any of your saved Dynamic Calibrations for running your process, simply click the SELECT Button from the OPT.MCAL page and chose the product that is currently running. Press the OK Button located in the Upper Right hand corner.



SCREEN GUIDE

Every HMI page has a unique name that includes the previous page name combined with a description of the current page. A period separates the names. When the DCE is first powered on, or when you press the soft-key labeled MENU, the TOP page is displayed.

TOP

TOP is the Main Menu Screen. There are six buttons on the TOP page. They are RUN, CAL, COM, SET, I/O and ADV. Press the RUN button to go to the TOP.RUN page. This is the normal display mode. Press the CAL button to go to the TOP.CAL page. This is where the DCE calibration is performed (comparable to analog electronics Static Calibration). Press SET Button to go to the TOP.SETUP page. This is used to perform the DCE site calibration. Press the I/O button to go to the TOP.I/O page. This is used to set up the digital inputs and outputs. Press the ADV button to go to the TOP.ADV page. This page is where advance functions such as batching and PID are set-up. In the lower corner you will also notice an indicator displaying whether you currently have a Flash Card Installed and if you have any alarms currently activated. In the upper right corner you can access a Help Menu.

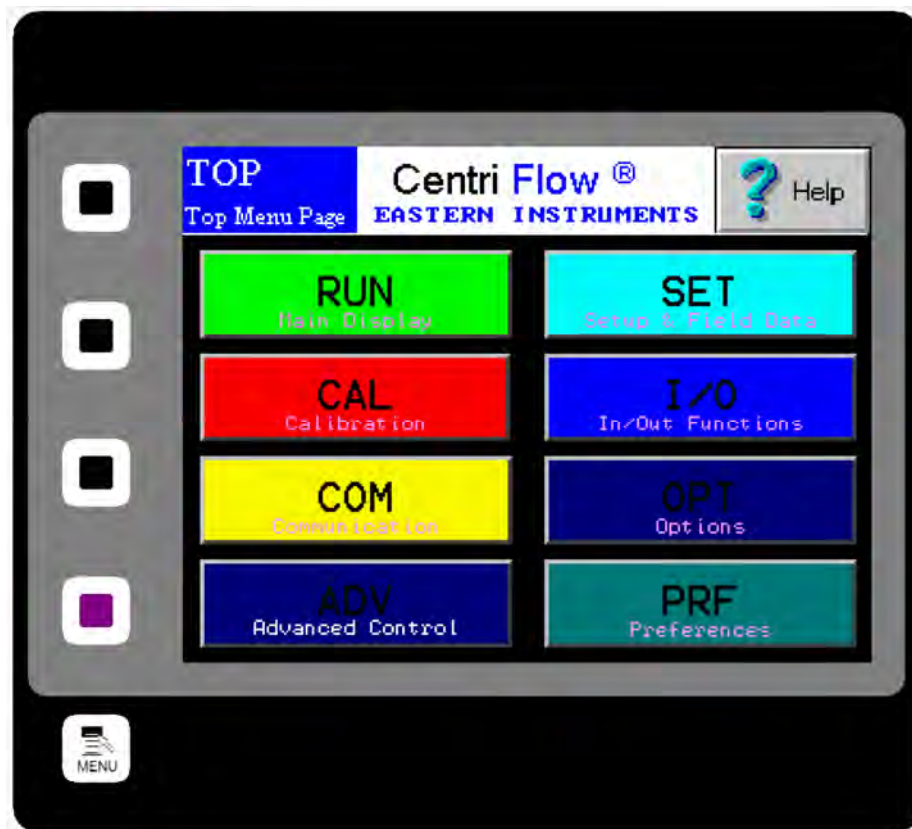

TOP.RUN

TOP.RUN is the main display mode. Access this screen by pressing the RUN Button from the TOP screen. The customer can choose between Automatic Mode and Manual Mode from this screen as well as view data in real time.

The Red and Green Bar on the Lower Right labeled SP and PV: SP stands for Set Point and represents the chosen value you would like the process to run at. It is represented as a percentage of your EFS value, or Electronic Full Scale. PV indicates your Process Value, or what the process is actually running at.

PV/SP in Engineering Units: The SP and PV values are also represented in Engineering Units in the square above the Run/Stop button on the lower left side of the screen.

The diagram of the valve/meter: A graphical representation of the valve and meter are seen on the center right of the screen and information relating to the valve can be viewed here. An Open/Closed indicator is above the valve graphic while the position of the valve is indicated in the white block under the word "position" on the valve graphic. The value is shown as a fraction of 100% open. The VFS Value, or Virtual Flow Stop Value is also indicated as a percentage of 100% open. Please see the manual for more information on the Virtual Flow Stop. Near the meter representation is an alarm indicator showing whether the alarm has triggered or not.

Total/Rate Indicator: In the top left corner under the Auto and Man Buttons are the numerical values of the calculated Total and Rate values for your process as well as the units of these values.

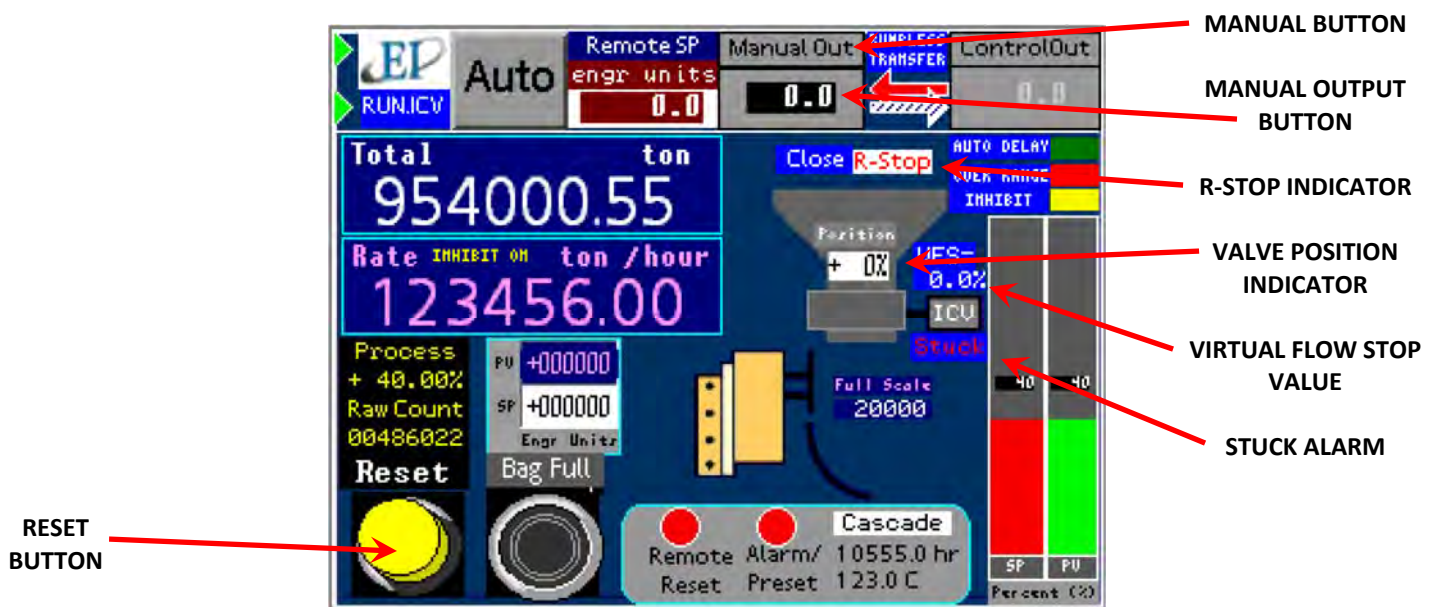

RUN.FILL

RUN.FILL is a secondary Run Page that can be accessed by accessing it from the Preferences Page. From the Main Menu press the PRF Button and then, press the Custom Page Select Button. Pressing the Primary Page or Secondary Page will cycle between various optional pages. Once the screen to the right is seen, press the OK Button in the top right hand corner. Selecting the RUN.FILL page as the Primary Page will allow you to see this page when on the Main RUN screen. If this page is selected as the Secondary Page, then it can be accessed by pressing the bottom soft key when on the Main Menu.

Learn Mode can be toggled using the LEARN Button and allows the Weight Correction value to be determined through successive runs by examining the overshoot from the previous run and adjusting the Weight Correction appropriately. The Learn Mode has three settings that can be toggled by pressing the Learn Mode Button (circled). The three modes are Learn Slow, Learn Medium, and Learn Fast. You can also turn the Learn Mode off by toggling this button.

Pressing the Reset Button will reset the Measured Value.





TOP.CAL

TOP.CAL is the Main Calibration Page. Access this screen by pressing the CAL Button from the TOP page. There are eight buttons on the TOP.CAL page. They are ZERO, CALs, CALd, SETTINGS, RANGE, INHIBIT, FILTER, and E-UNITS. Press the ZERO button to go to the CAL.ZERO page. This is where you can perform a Zero Calibration. Press the CALs Button to go to the CAL.CALs page. This is where you can perform Static Calibration. Press the CALd Button to go to the CAL.CALd page. This is where you can perform Dynamic Calibration. Press the SETTINGS Button to go to CAL.SETTINGS. This is where you can view your currently selected settings. Press the RANGE Button in order to go to the CAL.RANGE page. This is where you select the current range of your electronics. Press the INHIBIT Button to go to the CAL.INHIBIT page. This is where you can select a threshold below which the Electronics will not take a flow measurement. Press the FILTER Button in order to go to the CAL.FILTER page. This is where you can filter the output of your 4-20 mA signal from instantaneous to averaged. Press the E-Units Button to go to the CAL.EUNITS page. This is where you can view data such as your Full Scale and your Count to Weight Ratio.

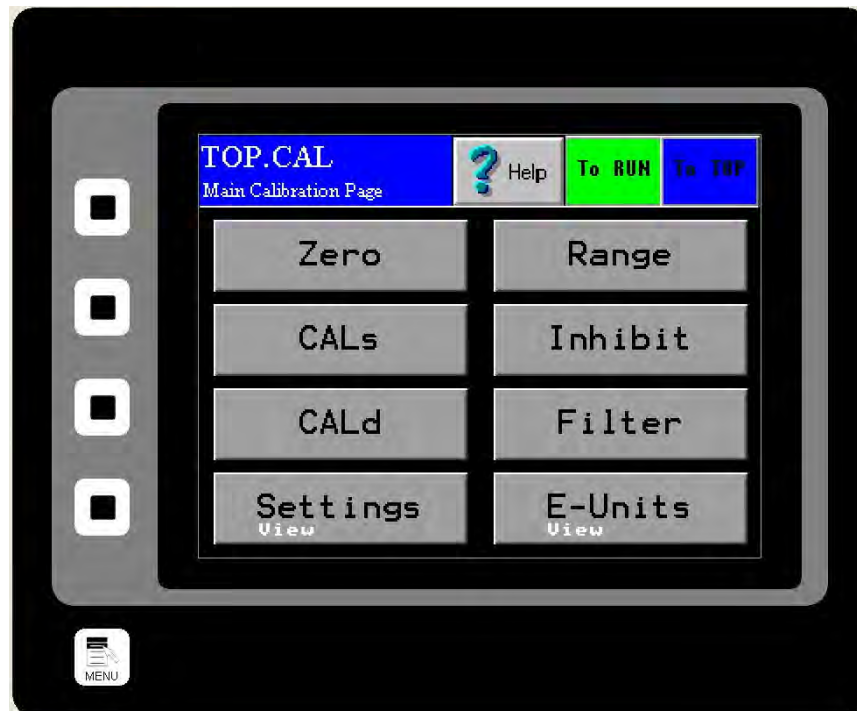



TOP.COM

TOP.COM is the Main Communication Page. Access this page by pressing the COM Button from the TOP page. There are five buttons on the TOP.COM page. They are INFORMATION, IP CONFIG, FACTORY, REMOVE CF and FORMAT CF. Press the INFORMATION Button to view information concerning your Software's version, your IP Address and whether you have a Compact Flash Card installed. Press the IP CONFIG Button to edit your IP Settings. Press the FACTORY Button to be able to restore Factory Settings. Press the REMOVE CF to be able to remove your Compact Flash in a safe manner. Press the FORMAT CF Button in order to format your Compact Flash Card.





TOP.SET

TOP.SET is the Main Data Entry menu. Access this page by pressing the SET Button from the TOP page. There are five buttons on the TOP.SET page. They are C/W RATIO, FIELD DATA, FIELD CALd, FIELD SAVE and FS MODIFY. From the SET Menu, seen below, you can enter values for your Count to Weight Ratio (C/W RATIO Button), enter Field Data such as is taken during Site Calibration (FIELD DATA Button), change your Dynamic Calibration Settings based on your Dynamic Calibration data (FIELD CALd Button), modify your Full Scale value (FS MODIFY Button), or save calibration data to your Flash Card (FIELD SAVE Button).

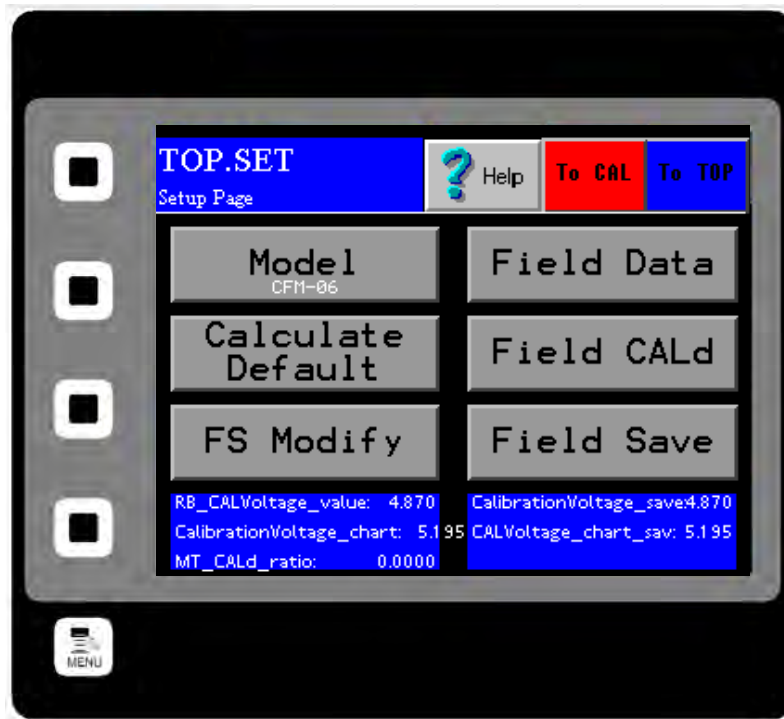

TOP.I/O

TOP.I/O is the Main Input/Output Menu page. Access this screen by pressing the I/O Button from the TOP page. This page is for accessing all options associated with setting the alarm on your process.

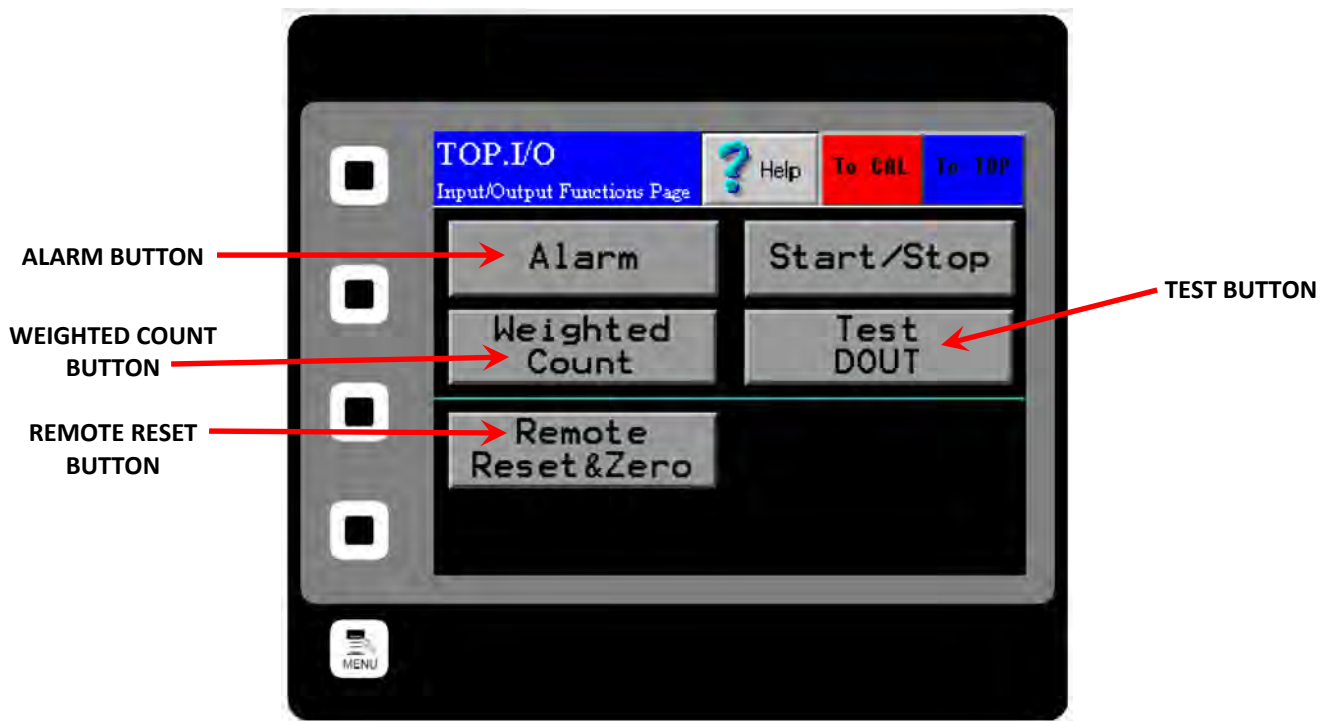

CAL.ZERO

CAL.ZERO is the Zero Calibration page. Access this screen by pressing the ZERO Button on the TOP.CAL screen after pressing the CAL Button from the TOP page. This page is for conducting Zero Calibrations. The procedure for a Zero Calibration can be found under the Static Calibration Section. (See page 21.)

The Diagnostic Window displays the Process Variable. The Red Zero Button is pushed in order to run a Zero Calibration. Information on whether the calibration was successful and whether there may be excess product on your Meter Pan may be found in your Information Window.

The meter should normally be re-zeroed when the Process Variable % is greater than +/- 0.25% with no flow. If highest accuracy is required, zero when greater than +/- 0.1%. Conversely, if lower accuracy is required this value can be raised. One can view the Process Variable % on the bottom right of the TOP.RUN page to determine if a zero is needed. (See page 32.)

Ensure there is no flow prior to performing a zero!

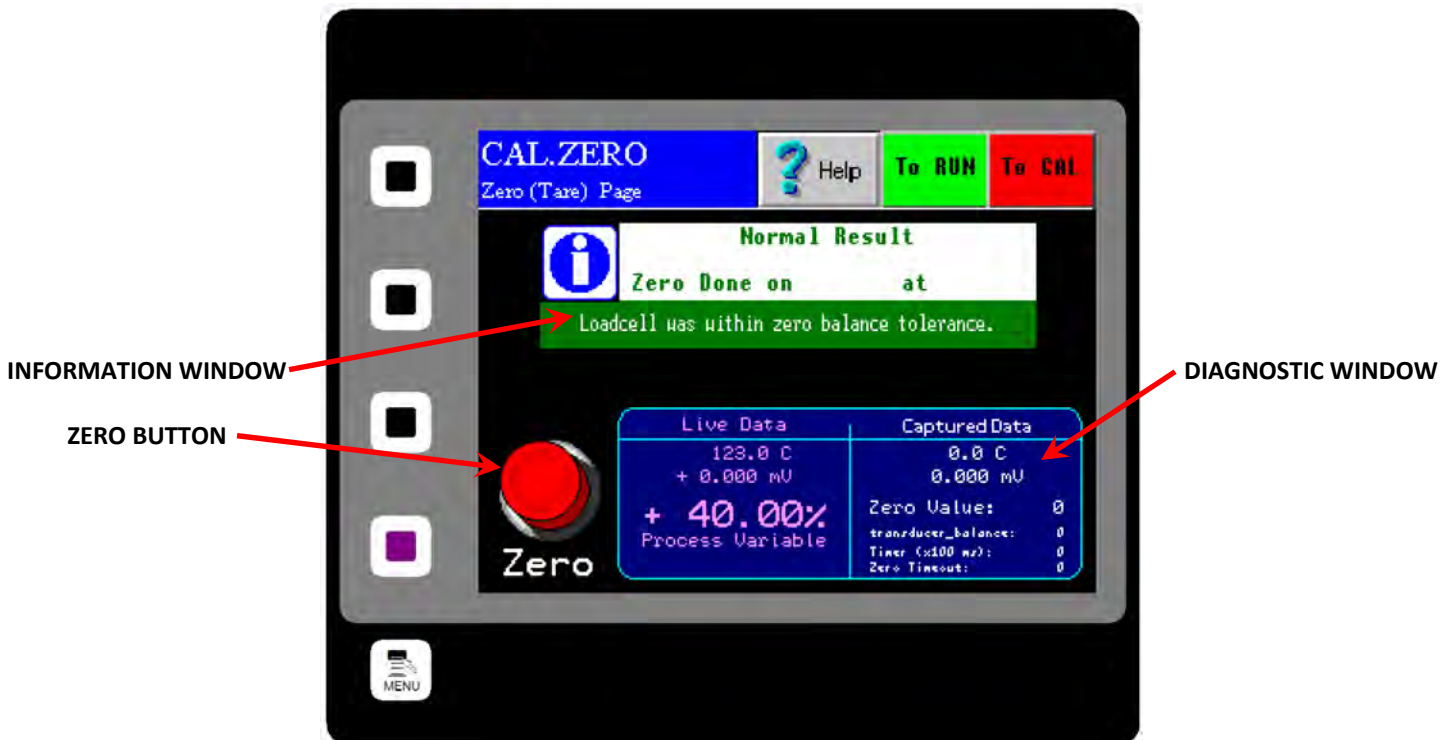

CAL.CALs

CAL.CALs is the Static Calibration page. Access this screen by pressing the CALs Button on the TOP.CAL page after pressing the CAL Button from the TOP page. This page is for conducting Static Calibrations. The procedure for a Static Calibration can be found under the Static Calibration Section. (See page 21.)

The Diagnostic Window displays Voltage. The Red CALs Button is pushed in order to run a Static Calibration. Information on whether the calibration was successful may be found in your Information Window. The screen capture below indicates a Static Calibration failure.

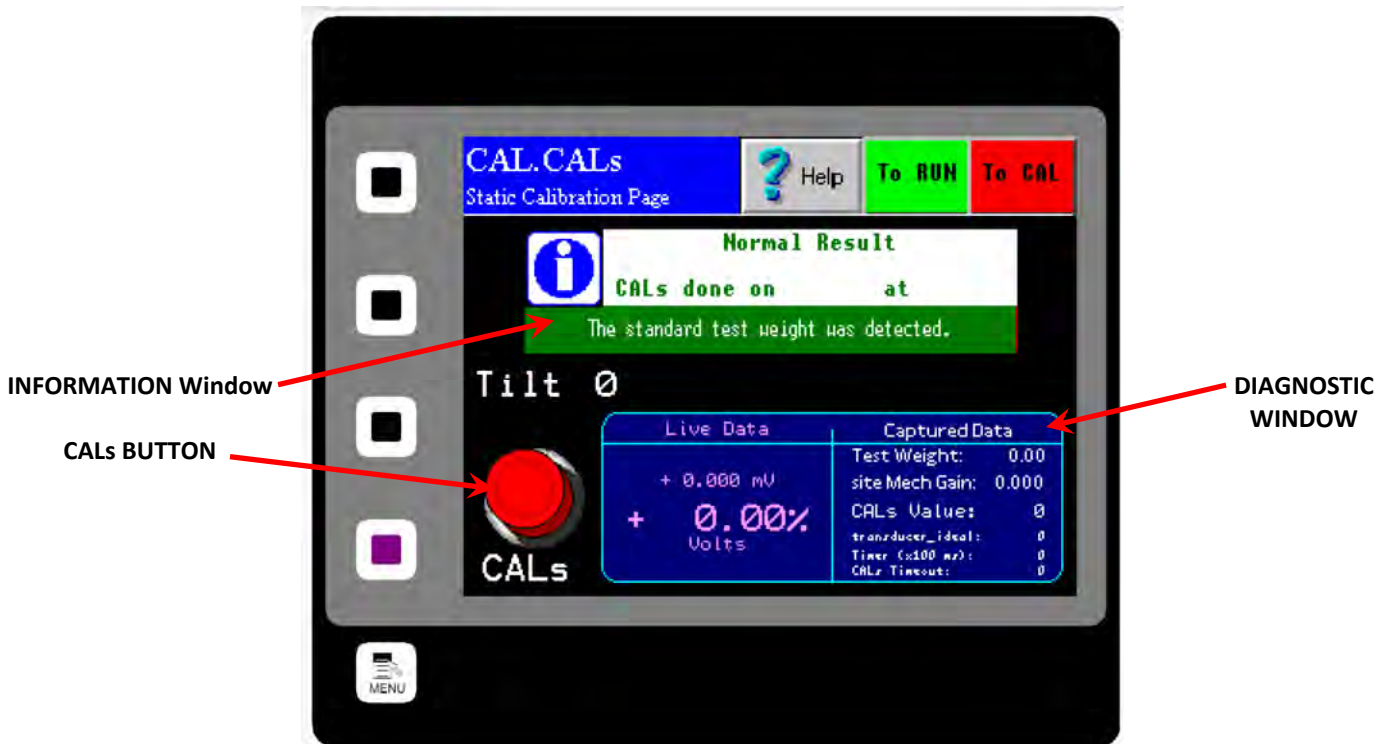

CAL.CALd

CAL.CALd is the Dynamic Calibration page. Access this screen by pressing the CALd Button on the CAL Screen after pressing the CAL Button from the TOP page. This page is for conducting Dynamic Calibration. The procedure for a Dynamic Calibration (or Site Calibration) can be found on page 22.

The Information Window displays helpful information regarding the options on this screen. Pressing the Dynamic Calibration Button **Twice** brings up a numeric keypad that allows you to manually enter your Dynamic Calibration Number.

Dynamic Calibration: Displays the setting used to adjust the Electronic Full Scale Flow Rate to the appropriate value. This Voltage can range from a minimum of 4 to a maximum of 10.

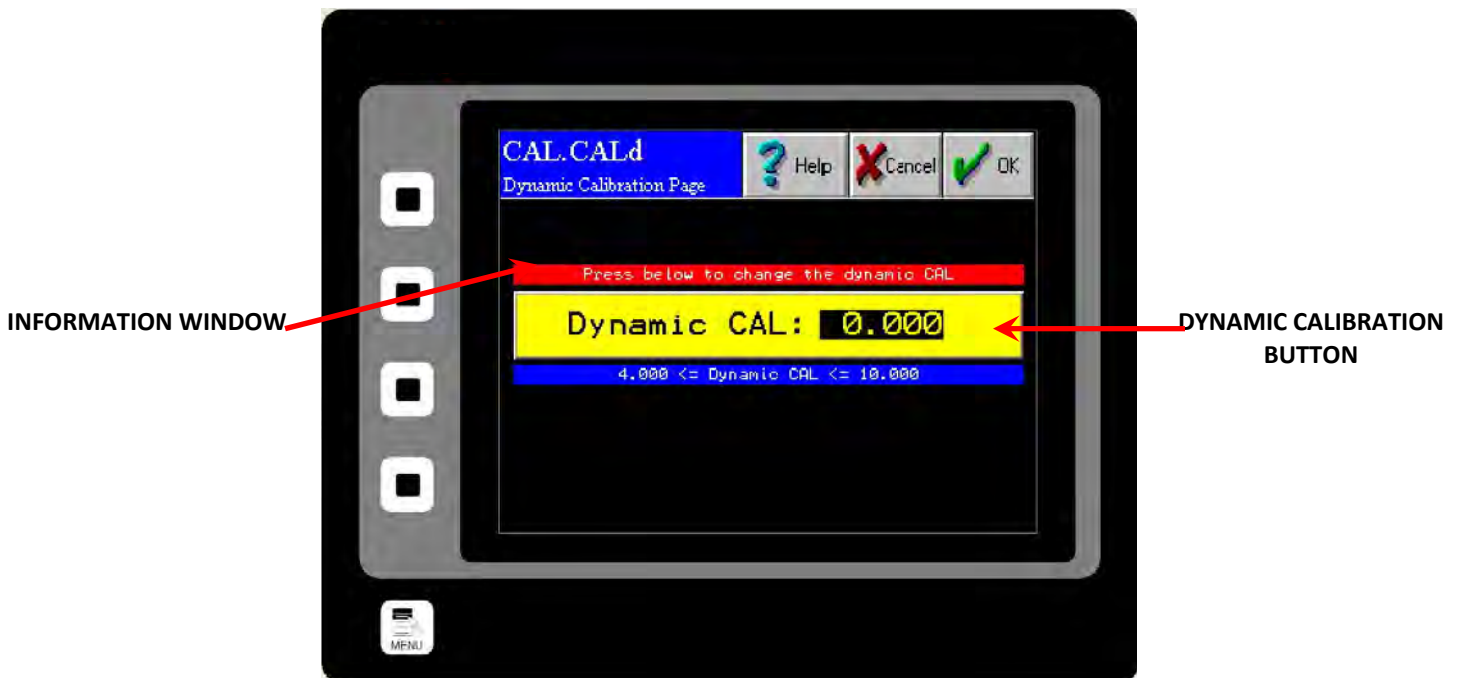



CAL.RANGE

CAL.RANGE is the Calibration Range page. Access this screen by pressing the RANGE Button on the TOP.CAL page after pressing the CAL Button from the TOP page. This page is for changing the Range of you electronics.

The Range can be changed to the desired value by clicking on the appropriate button.
The range setting is already selected by the factory and typically adjustment is not required.

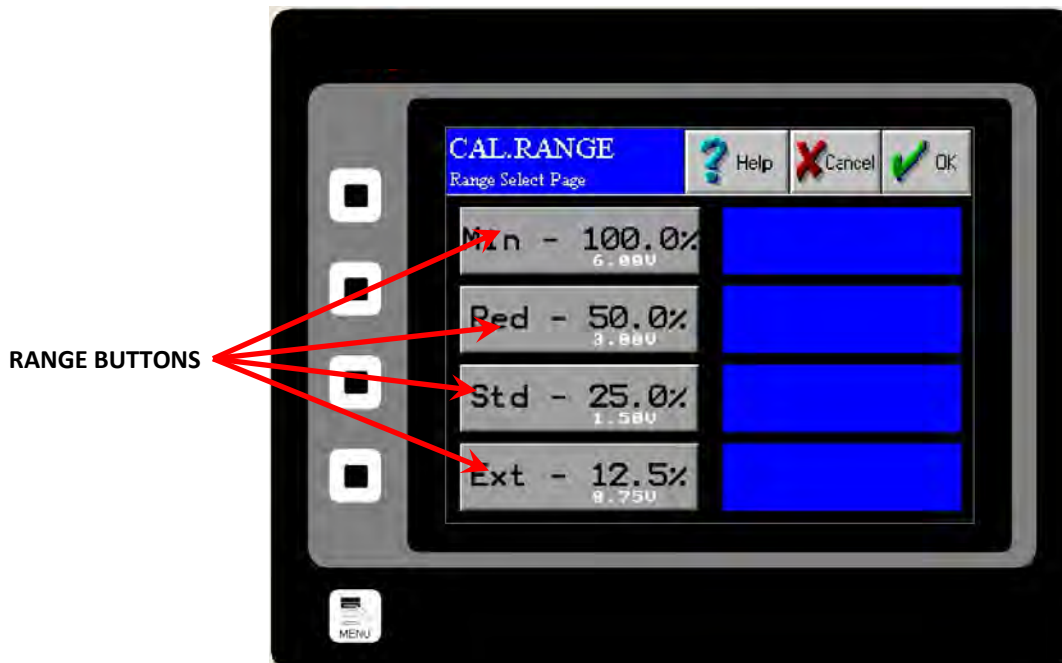

CAL.INHIBIT

CAL.INHIBIT is the Inhibit page. Access this screen by pressing the INHIBIT Button on the TOP.CAL page after pressing the CAL Button from the TOP page. This page is for changing the Inhibit that sets a threshold which the Flow Rate Output must rise above in order for the electronics to begin counting. The range for setting this threshold is from 0.5% of full scale to 4.0% of full scale.

The Inhibit can be changed by pressing the accompanying Inhibit Buttons.

Unless OFF is selected for Inhibit, the Total display on the page TOP.RUN and the output signal 'Frequency, Flow Rate Proportional' will be inhibited. The Inhibit for the Flow Rate display on the page TOP.RUN and the output signal '4-20mA' operate slightly different. The Inhibit is OFF for the Flow Rate and 4-20mA signal when the 4-20mA moving average filter is OFF. (See the page CAL.FILTER.) To Inhibit the Flow Rate and 4-20mA signal, both the 4-20mA moving average filter and the Inhibit must be on.

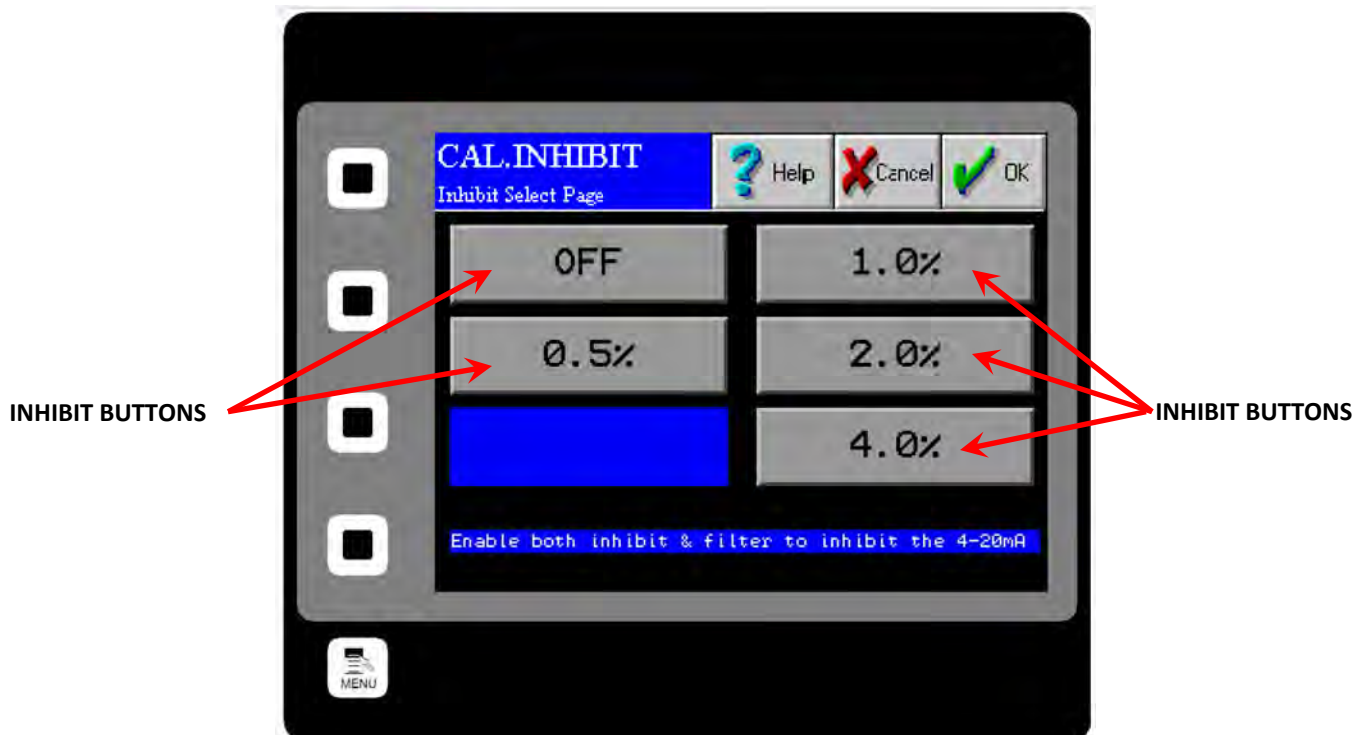

CAL.FILTER

CAL.FILTER is the Filter page. Access this screen by pressing the FILTER Button on the TOP.CAL page after pressing the CAL Button from the TOP page. This page is for selecting the number of points used in the 4-20mA moving average filter. The formula for a moving average filter is shown below. Press one of the Filter Buttons to select the desired time increment for the filter. For example, a time increment of 1 second will filter (or average) 200 samples of the input signal to create the 4-20mA filtered output signal. This is because the transducer input sample rate is 200 samples per second. The 4-20mA output signal is updated at the same sample rate as the input signal. However, the output signal will be delayed by the selected time. The moving average filter can also be turned off from this screen.

Moving Average Filter

$$y[i] = \frac{1}{M} \sum_{j=0}^{M-1} x[i+j]$$

$x[] = \text{input signal}$
 $y[] = \text{output signal}$
 $M = \text{number of points}$

The moving average is a very common filter in digital signal processing. Despite its simplicity, the filter is optimum at performing the common task of reducing random noise while retaining a sharp step response.

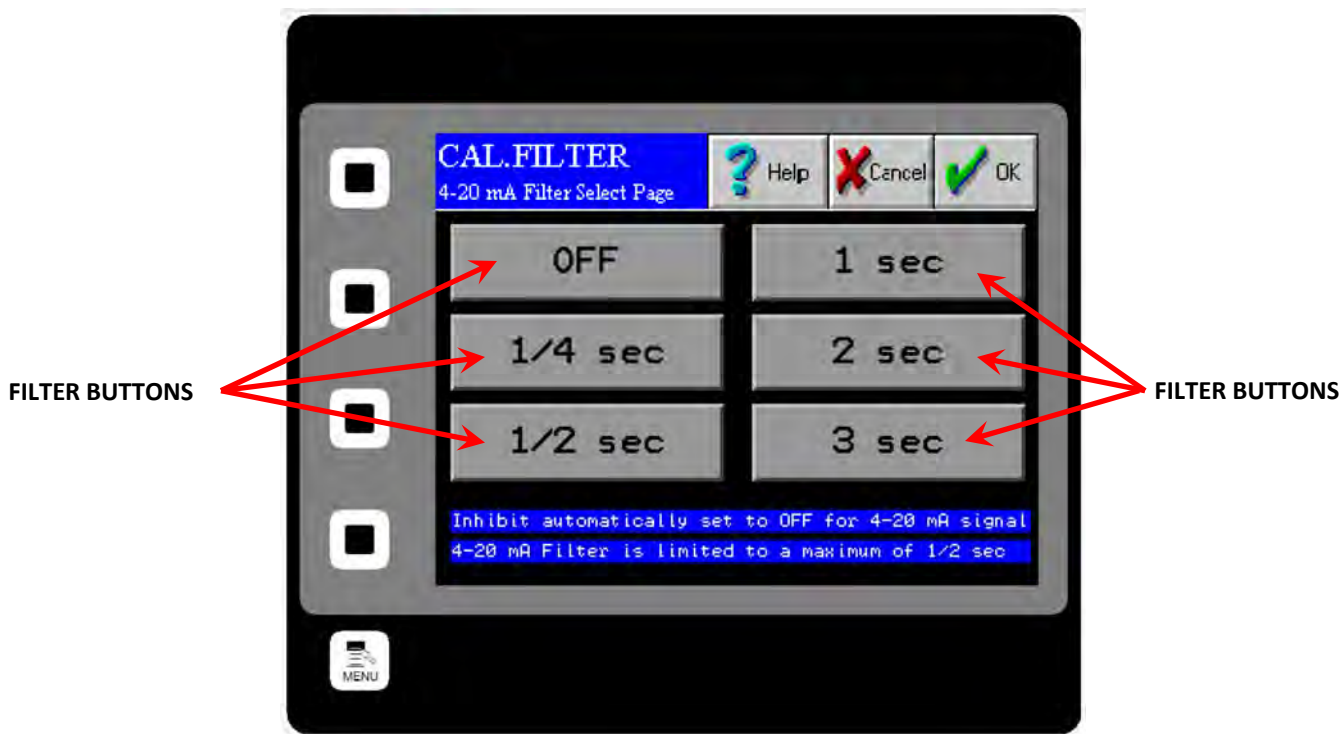



CAL.EUNITS

CAL.EUNITS is the Unit Display page. Access this screen by pressing the EUNITS Button on the TOP.CAL page after pressing the CAL Button from the TOP page. This page displays the Electronic Full Scale, the mass and time units, and the C/W Ratio. The C/W Ratio, or Count per Weight Ratio, is determined by the factory. This value is the number of counts that the Electronics Counter will display per weight of material that is run through the meter.

These settings can not be modified from this page.

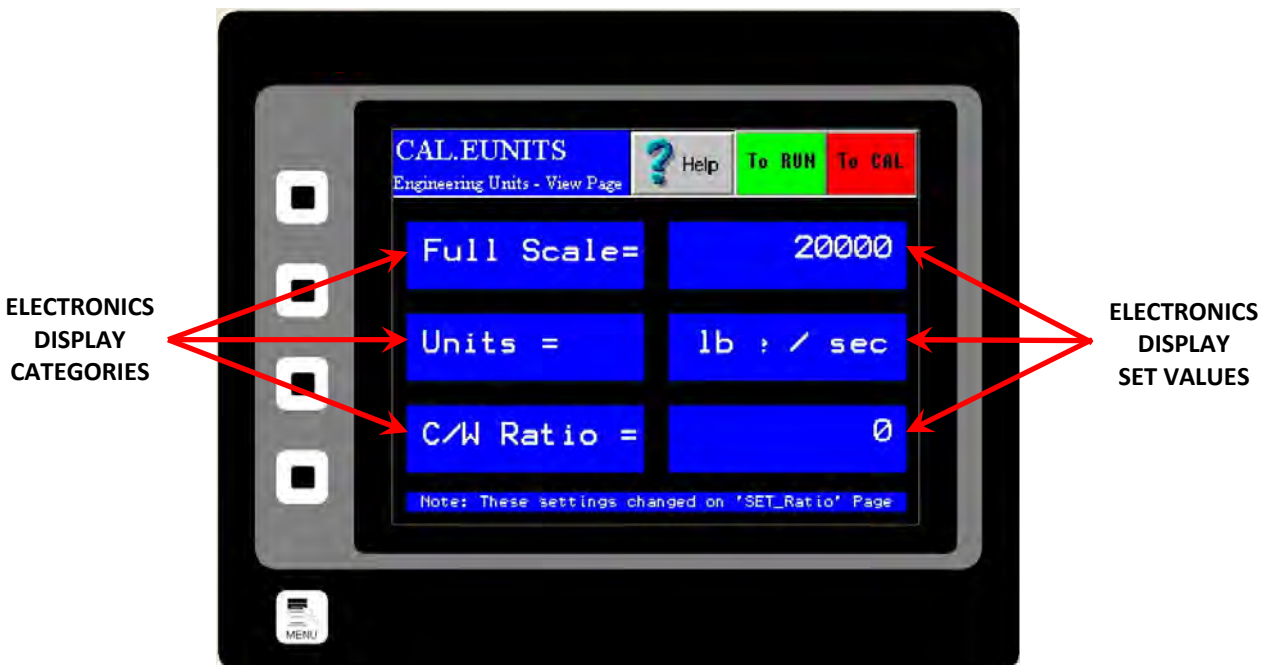

SET.RATIO

SET.RATIO is the page that allows you to calculate your count per weight ratio. The C/W Ratio, or Count per Weight Ratio, is determined by the factory. This value is the divisor used to calculate the engineering count (total) from the raw count. Your Full Scale value can be changed, the units of your Full Scale value can be modified and the number and size of your Transducers can be modified from this page. The button near the bottom will use this data and recalculate your C/W ratio.

Engineering Count = Raw Count / Count per Weight Ratio

This data is set by the factory and should not be changed by the customer.

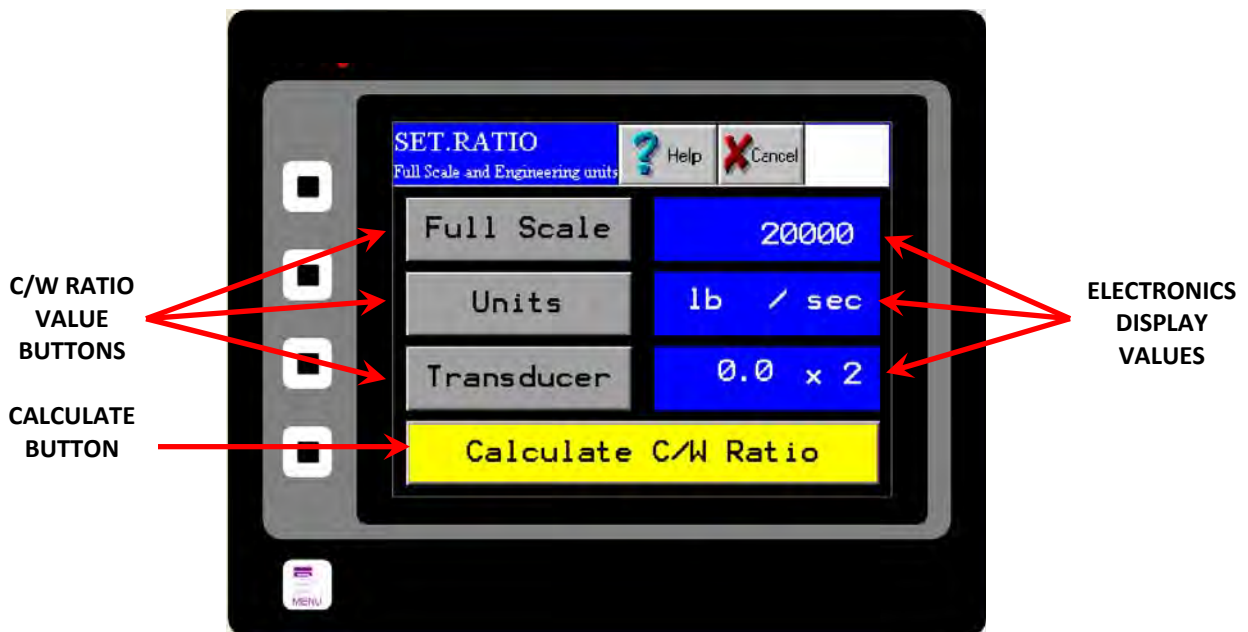



SET.FIELD

SET.FIELD is the page that allows you to collect and verify your site calibration data. This page is used extensively in Site Calibration as shown in the Site Calibration section of Chapter 3 of this manual. This screen allows you to compare the metered weight of material run through the meter versus the actual weight of the material, often weighed by a static scale after being diverted. By pressing the FIELD DATA CURRENT RUN Buttons (1-5) you can select which runs will be used during your Site Calibration calculation. The green RUN SELECTOR INDICATOR lights will be lit green when selected. Selecting certain runs using your FIELD DATA CURRENT RUN Buttons will also be useful when used in conjunction with the FUNCTION Buttons at the bottom of the screen for clearing a certain run or entering the actual data for a specific run. Values for the actual weight of material run through the meter can be entered by touching the appropriate area in the "Actual" column. A numeric keypad will prompt you to enter your data.

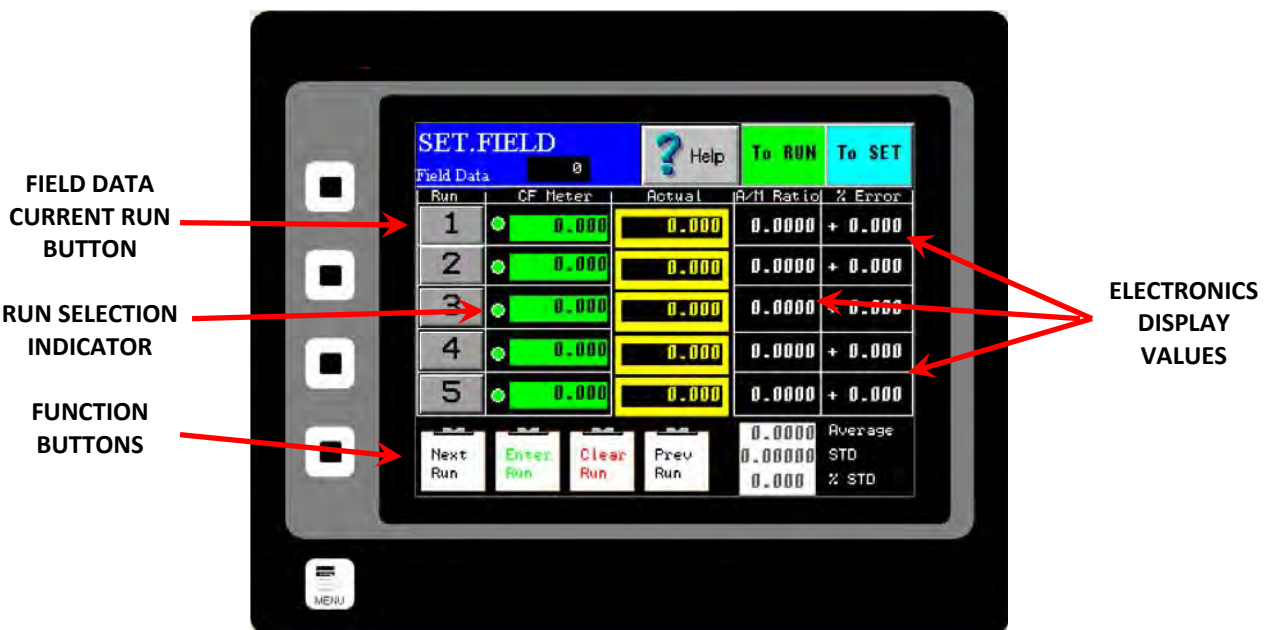



SET.CALd

SET.CALd is a page used in conjunction with SET.FIELD page in order to adjust your Dynamic Calibration using recently collected field data. Once the field data is entered, open this page and you should see the new calculated Dynamic Calibration value under the CALCULATED DYNAMIC CALIBRATION SETTINGS section. Your current calibration settings will be displayed under the CURRENT DYNAMIC CALIBRATION SETTINGS section. The CALCULATED TO CURRENT Button allows you to change your Dynamic Calibration using the new, calculated value. For detailed instructions on how to perform a Dynamic, or Site, Calibration, please see the Site Calibration section of Chapter 3.

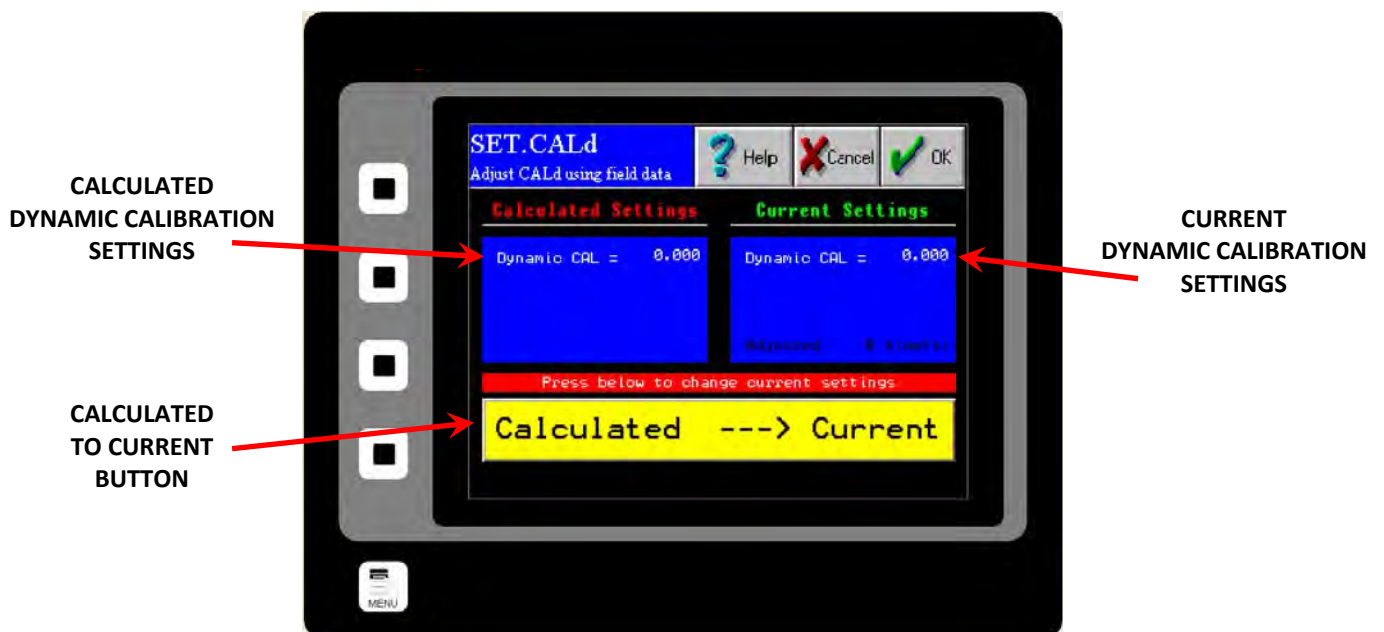



I/O.WCOUNT (Optional)

The I/O.WCOUNT page allows you to set up the weighted count option. This option allows you to set a target weight that will trigger a pulsed signal each time that target weight passes over the meter. The TARGET Button allows you to determine when the pulse will trigger by selecting the target weight, while the PULSE WIDTH Button allows you to determine the length, or duration, of the pulse signal. The values become effective immediately upon entry. You do not need to press the CALCULATE Button for the new Weighted Count values to become effective. The CALCULATE BUTTON is used as a reference guide only and will estimate, using your Full Scale value and your flow rate, the time taken to reach the target weight and thus, an estimate of the time between each pulse signal. The CALCULATE Button offers a way to ensure that the Target value is compatible with your Pulse Width value.

For example, if you are using your Weighted Count option to monitor product flowing at 60,000 lb/min in order to send a pulsed signal to an indicator light every time 1,000 lb passes through the meter and your pulse width is set to one second, the indicator light will never go off before it is signaled to come back on again.

If this is the case, a warning message like the one shown below, will appear. Raising your target value, lowering your pulse width, or both will remedy this.

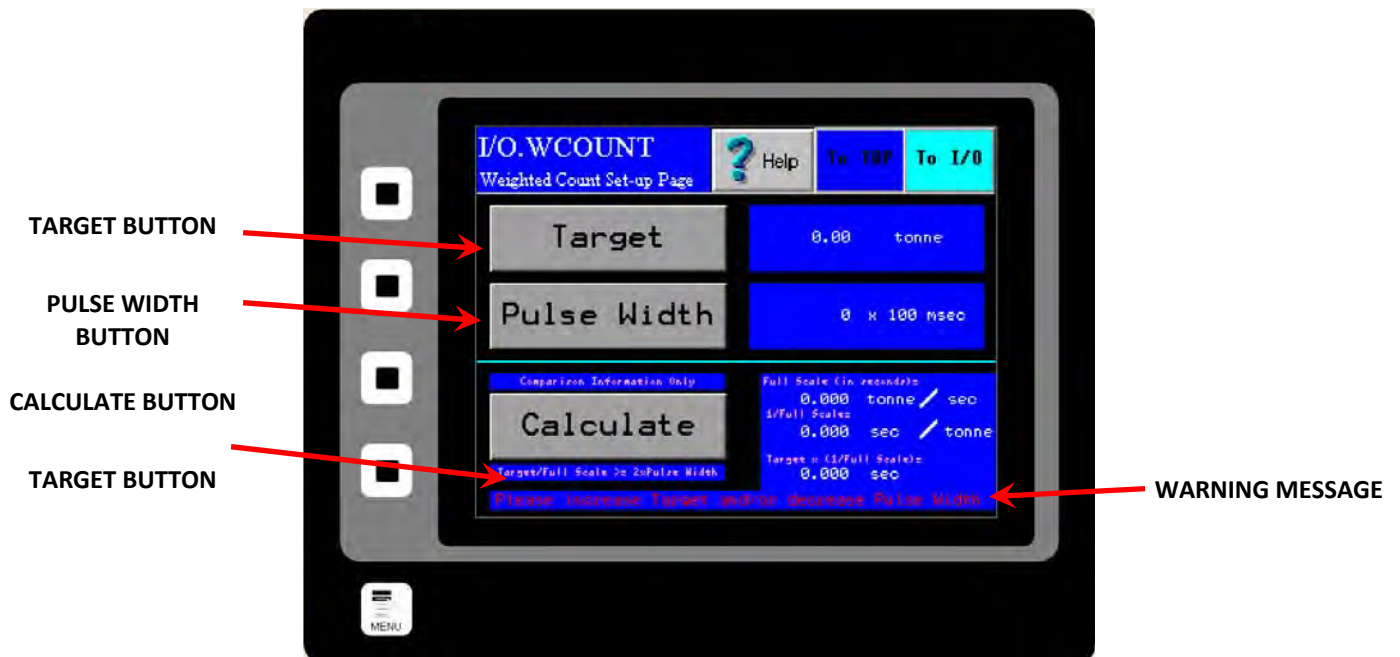

I/O.ALARM

I/O.ALARM is the Alarm page. Access this screen by pressing the ALARM Button from TOP.I/O page. This page is for changing the options of the alarm. The alarm can be turned on and off using the ENABLE Button. Press the ENABLE Button until the desired result is displayed in the Blue display box to the right of the ENABLE Button.

The alarm can be used to monitor either flow rate or weight using the TYPE Button. Press the TYPE Button until the desired result is displayed in the Blue display box to the right of the TYPE Button.

The Target Value for both rate and weight alarms can be set by pressing the TARGET Button and entering an appropriate value. Pressing the TARGET Button will take you to the I/O.ALARM.SP page. For more information on this page, please turn to the next page.

The alarm can be set as either a High Alarm or a Low Alarm. Use the LOGIC Button to choose which type of alarm you would like to use. Press the LOGIC Button until the desired result is displayed in the Blue display box to the right of the LOGIC Button.

NOTE: POSITIVE LOGIC INDICATES THAT THE ALARM HAS BEEN SET AS A HIGH ALARM AND WILL TRIGGER WHEN FLOW (OR WEIGHT) GOES ABOVE THE TARGET VALUE. NEGATIVE LOGIC INDICATES THAT THE ALARM HAS BEEN SET AS A LOW ALARM AND WILL TRIGGER WHEN FLOW (OR WEIGHT) GOES BELOW THE TARGET VALUE.

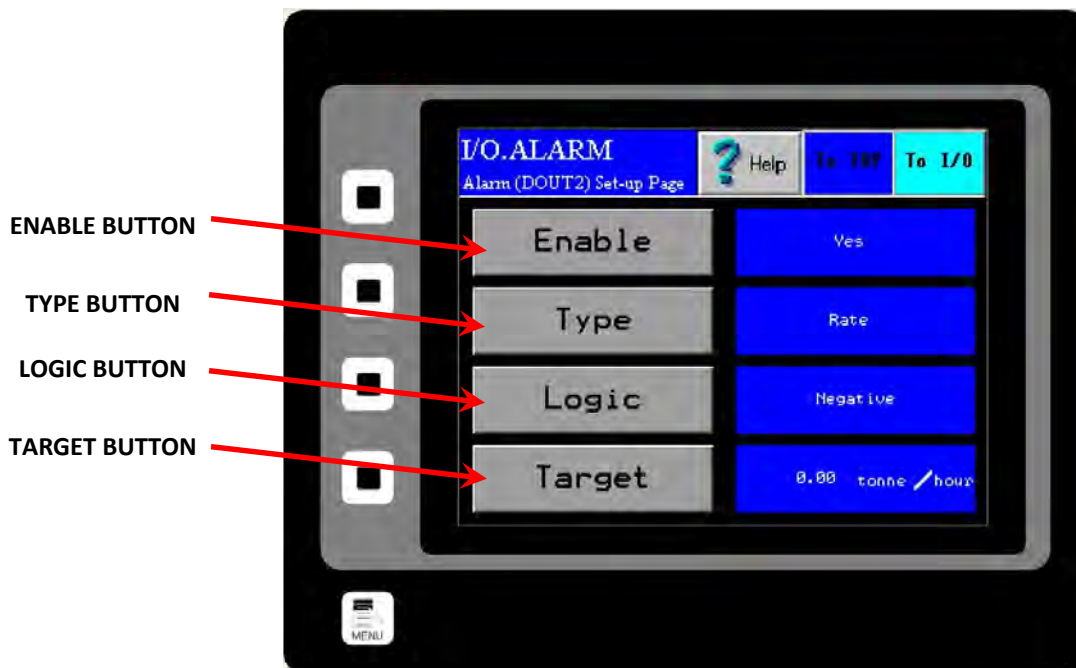



I/O.ALARM.SP

I/O.ALARM.SP is the Alarm Target Entry page. Access this screen by pressing the TARGET Button from the I/O.ALARM page. This page is for changing the values that will trip the alarm. You can enter a weight by pressing the WEIGHT ALARM Button or enter a rate by pressing the RATE ALARM Button. The value entered will display to the right of the button.

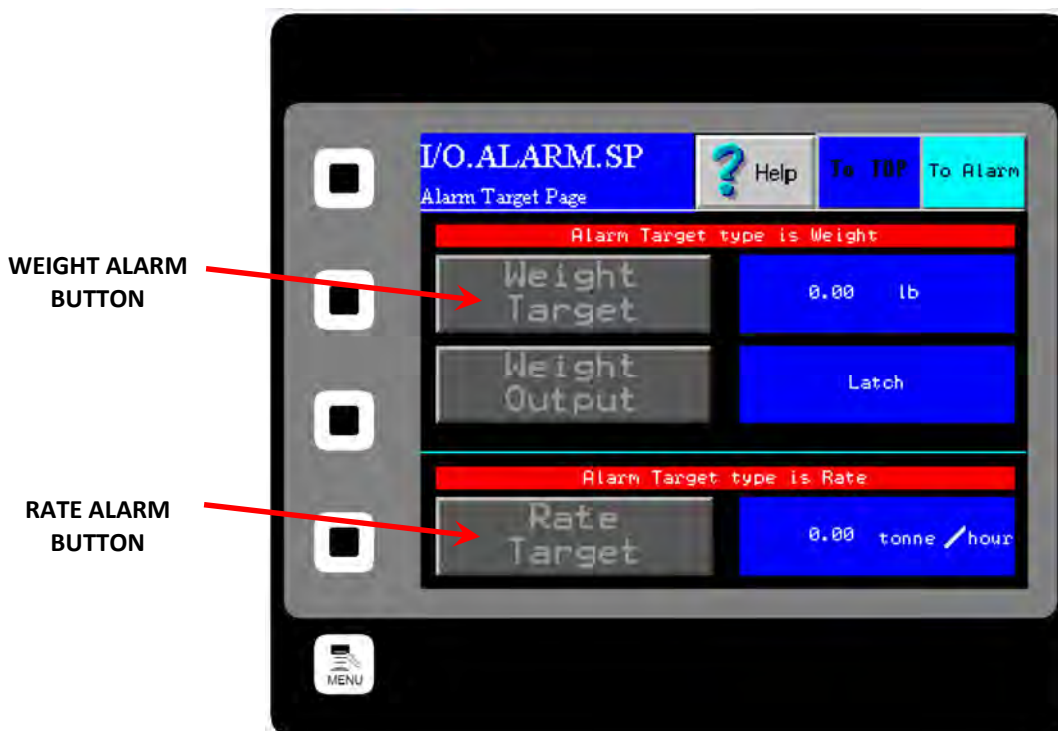

I/O.WEIGHT.OUT

I/O.WEIGHT.OUT is the page that allows you to define the type of Weight of Totalization alarm that you will be utilizing. Access this screen by first pressing the I/O Button from the TOP.MENU page. Then, press the ALARM Button, followed by the TARGET Button, and finally, the WEIGHT OUTPUT Button. The two types of Weight Alarms to choose from are Pulsed Weight Alarms, or Latch Weight Alarms. A Pulsed Weight Alarm will allow you to choose a Weight Target and when that amount of weight, or Total Weight, passes through the meter, the alarm will be tripped for a set duration of time. A Latch Weight Alarm will trip as soon as the Target Weight is reached and will remain tripped, or “latched”, until the Totalization count is reset. For instructions on Totalization reset, please see the TOP.RUN page in the Screen Guide section of Chapter 4.

Pressing the OUTPUT Button will allow you to choose between a Pulsed Weight Alarm or a Latch Weight Alarm. If a Pulsed Weight Alarm is chosen, a duration for the Pulsed Alarm can be chosen as well. This is accomplished by pressing the DURATION Button and entering an alarm duration in seconds. The Totalization Count is reset once the Pulse Alarm time expires.

*Please note that while a duration can be entered even while a Latch Weight Alarm is selected, the duration entered will have no effect unless a Pulse Weight Alarm is chosen.

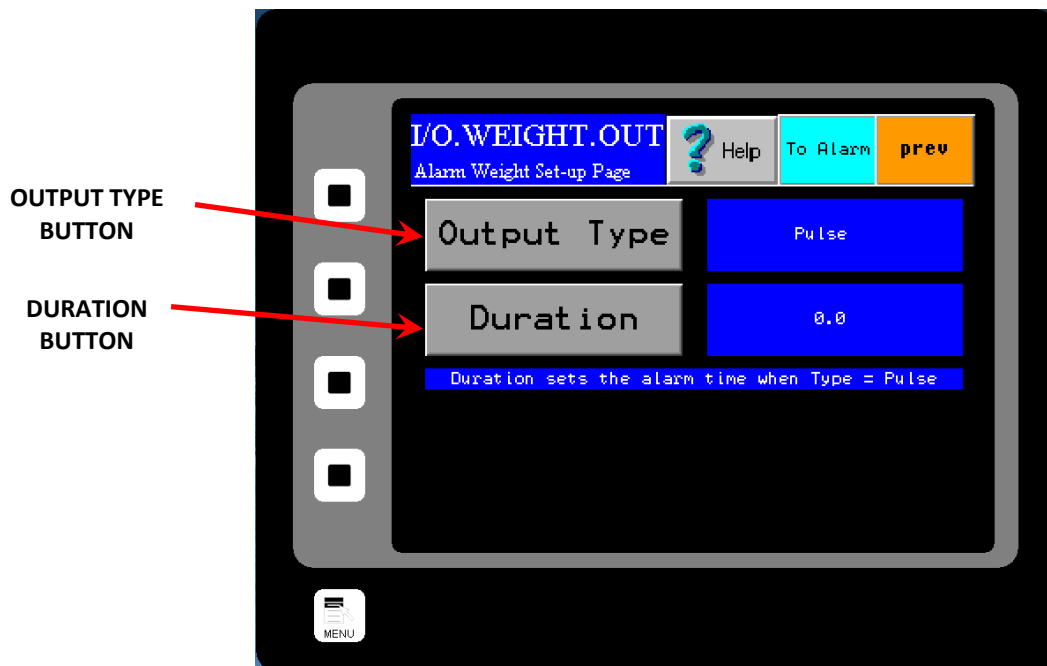

OPT.PLC

OPT.PLC is the page that allows you to determine whether you are utilizing local control (control through use of the digital electronics' HMI) or whether you have remote control (control through use of PLC commands). Access this screen by first pressing the OPT Button from the TOP.MENU page. Then, press the Ethernet/IP Button. Control can be toggled between PLC control and HMI control by pressing either the ENABLE Button (for Remote PLC Control) or the DISABLE Button (for Local HMI Control). You can also set up remote control by pressing the Setup Button.

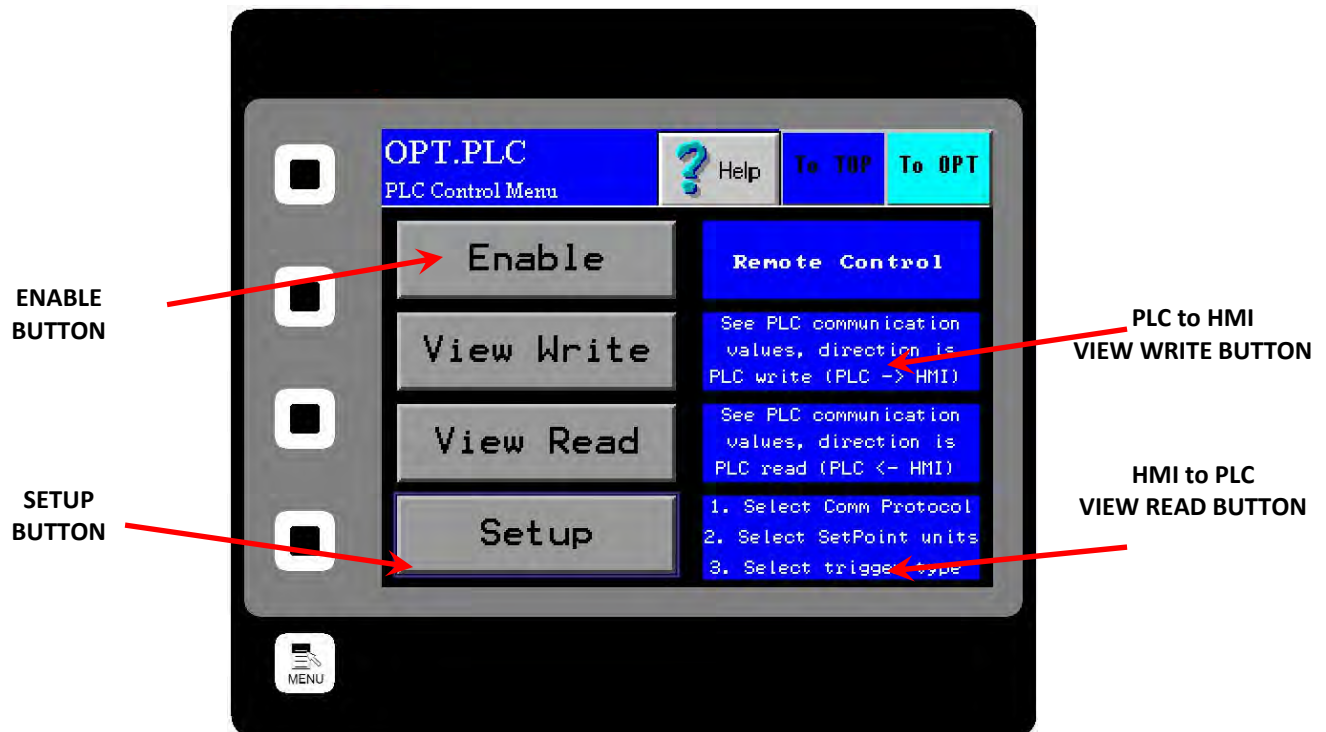



REFERENCE

Definition of Terms

Automatic Control: Adjustment of the Integrated Control Valve's position so that the Process Value is equal to the Set Point Value. Output of this operation is referred to as "Auto Out".

Anti-Binding Function: A programmed algorithm which will try to free the ICV if the controls system detects that valve is stuck. The valve will attempt to free itself five times by transferring to a "maximum impulse" condition. After the 5th attempt, if the valve remains stuck, it will go into rest mode for 3 minutes in which the valve will continue moving, but at a reduced power in order to prevent overheating. The valve will cycle every 3 minutes through this same process in an attempt to reach its target value. Changing the target value will reset the algorithm.

Control Mode: Mode of control. Either Auto or Manual.

Control Out: The resultant output of either Manual or Automatic Control. It is usually represented as a percentage of Electronic Full Scale.. It is the value sent to the final control device.

Control Type: Determines how the control output is sent to the final control device: Linear Proportional, Bifurcating Time Proportioning, Scalable Time Proportioning.

Dynamic Calibration: Setting that adjusts the Calibration of the Electronics so that 100% Output is equal to the Electronic Full Scale Flow Rate (Mass). This number ranges from a minimum of 4 to a maximum of 10.

Electronic Full Scale Flow Rate (Mass): Flow Rate that Electronics is calibrated at such that the Electronics output is 100%.

Extended Static Calibration: This is a non-standard setting of the Static Calibration that will electronically range the Transducer up to 2 times the standard Transducer Value. The Range setting for this is 0.75 Volts.

Inhibit Threshold: Voltage level that is adjusted to allow Electronics not to measure product that might be present only at certain periods. An example of this would be at start up when there might be product dribbling onto meter. This Voltage would represent a percent of the 100% output of the Electronics. That is, if the 100% output represented an Electronic Full Scale Flow Rate of 300 lb./min, then an Inhibit Threshold setting of 2% of the Electronic Full Scale Flow Rate would be 6 lb./min.

Manual Control: Manual setting of the Integrated Control Valve to a specified value with an acceptance of the resulting Process value. Output of this operation is referred to as "Manual Out".

Minimum Static Calibration: This is a non-standard setting of the Static Calibration that will electronically range the Transducer down to $\frac{1}{4}$ times the standard Transducer Value. The Voltage setting for this is 6.0 Volts. (This is used only under special circumstances).

Manual Value: The set value of the Manual Output, usually in percent.

NC: Normally Closed. This term refers to electronic signal outputs and means that the output is normally closed until a signal is received at which point the output will open.

NO: Normally Open. This term refers to electronic signal outputs and means that the output is normally open until a signal is received at which point the output will close.

PID Control: The independent sum of the proportional ($K_p * E$), integral ($K_i * E_{sum}$), and derivative ($K_d * E_{delta}$) terms to produce an auto out. The Error (E) is the difference between the Set point and the Process Variable. The values of the proportion gain (K_p), integral gain (K_i), and derivative gain (K_d) are dimensionless and can be entered as a number from 0.001 to 999.999. Entering a zero value disables that function. Increasing the value decreases the control stability while increasing the responsiveness of the system.

Process Value: The actual value of the process in engineering units or in percent of Electronic Full Scale

Process Value/Set Point in Engineering Units: Representation of the Process Value in actual units, such as lb/min.

Reduced Static Calibration: This is a non-standard setting of the Static Calibration that will electronically range the Transducer down to $\frac{1}{2}$ times the standard Transducer Value. The Voltage setting for this is 3.0 Volts .

Retained Auto Output: The saved value when Auto Control is switched to Manual Control. It is the Control Out Value that satisfies the condition that Process Value is equal to Set Point Value at the moment that the switching occurs.

Static Calibration (Static Cal): Voltage setting that Ranges Transducer in a STATIC State. This setting is made while the Test weight is hung from the Calibration Stud on the Pan End and no product is on the Pan.

Set Point: The desired value of the process under automatic control, in engineering units or percent of Electronic Full Scale

Virtual Flow Stop: Setting that stops flow without closing the Integrated Control Valve (ICV) completely and damaging the product and minimizes damage to the leading edge of the ICV and the Tangential Plate.

Weighted Count: The weighted count is the engineering unit count divided by a scale factor to generate a much slower count (i.e. 1 pulse/100 lb or 1 pulse/1,000 lb.). Typically, the weighted count is used as an input to a PLC and is transmitted to the PLC via a solid state relay (SSR).



CERTIFICATE & DECLARATION OF CONFORMITY FOR CE MARKING

Company contact details:

Eastern Instruments
416 Landmark Drive, Wilmington, NC 28412, USA

Eastern Instruments declares under their sole responsibility that their:

Digital CentriFlow Electronics
listed as the following model numbers
CV-UV-25-H1-CV-ET-MC-WC-IT-AZ-FL-EH-AF-5K-PA
CV-UV-25-H1-CV-DN-MC-WC-IT-AZ-FL-EH-AF-5K-PA
CV-UV-25-H1-CV-PB-MC-WC-IT-AZ-FL-EH-AF-5K-PA
CV-UV-25-H1-CV-CAN-MC-WC-IT-AZ-FL-EH-AF-5K-PA
SV-UV-25-H1-CV-ET-MC-WC-IT-AZ-FL-EH-AF-5K-PA
SV-UV-25-H1-CV-DN-MC-WC-IT-AZ-FL-EH-AF-5K-PA
SV-UV-25-H1-CV-PB-MC-WC-IT-AZ-FL-EH-AF-5K-PA
SV-UV-25-H1-CV-CAN-MC-WC-IT-AZ-FL-EH-AF-5K-PA

comply with the Essential Requirements of the following EU Directives:

Low Voltage Directive 2006/95/EC
Electromagnetic Compatibility Directive 2004/108/EC
RoHS 2 Directive 2011/65/EU

and further conform with the following EU Harmonized Standards:

EN 61010-1:2010
EN 61326-1:2013

Dated: 13 November 2015

Position of signatory: Technical Director

Name of Signatory: Robert Otto Brandt, Jr.

Signed below:

on behalf of Eastern Instruments



Panel Shop Certification Record

Listing# E212589
Original Certification: June 30, 2015
Revised Certification: N/A

This Certification is issued to:
Eastern Instruments
416 Landmark Drive
Wilmington, NC 28412

For the product(s):
Open/Enclosed Industrial Control Panels

Have been certified to the following standard(s):
UL 508A: Standard for Safety, Industrial Control Panels, Revision Date: January 13, 2014
CSA C22.2 #14: Industrial Control Equipment, Revision Date: March 2013

Rick Cooper,
Director of Laboratory Operations
Safety Laboratory



All changes proposed in the previously identified product that affects the above information must be submitted to MET for evaluation prior to implementation to assure continued MET Certification status.

The covered product(s) shall be subject to follow-up inspections to ensure that the Certified product(s) are identical to the product sample evaluated by MET Laboratories, Inc. and that all manufacturer's responsibilities are being fulfilled as specified in the Manufacturer's Responsibility section of the Certification report. The applicant named above has been authorized by MET Laboratories, Inc. to represent the product(s) listed in this record as "MET Certified" and to mark this/these product(s) according to the terms and conditions of the MET Applicant Contract, MET Listing Reports, and the applicable marking agreements. Only the product(s) bearing the MET Mark and under a follow-up service are considered to be included in the MET Certification program. This certification has been granted under a System 3 program as defined in ISO Guide 67.



MET Laboratories, Inc. is accredited by OSHA and the Standards Council of Canada.
The Nation's First Nationally Recognized Testing Laboratory

